

NEUTRON DIFFRACTION STUDIES ON TRANSITION METAL HYDRIDE COMPLEXES

Robert Bau

Department of Chemistry, University of Southern California
Los Angeles, California 90007

Thomas F. Koetzle

Department of Chemistry, Brookhaven National Laboratory, Upton, New York 11973

Abstract - Recent neutron diffraction investigations on terminal, bridging and triply-bridging metal-hydrogen bonds are reviewed.

INTRODUCTION*

The field of metal hydride complex chemistry has traditionally been a poorly-understood area in inorganic chemistry (1). This is so largely because of the difficulties in determining the presence, and also the number, of hydrogen atoms in such molecules. Because of its weak X-ray scattering cross-section the hydrogen atom is not easily detected by X-ray methods, particularly when it is bonded to a metal atom. Thus, in the early literature there was much confusion about the geometries of the simpler metal hydrides such as $\text{HCo}(\text{CO})_4$ and $\text{H}_2\text{Fe}(\text{CO})_4$ (2). The issues then in question were (i) whether the hydrogen atom occupied a distinct coordination position about the metal atom and (ii) whether the metal-hydrogen distance was "short" (1.2-1.4 Å) or "long" (≈ 1.6 Å). In the past decade, however, these questions have largely been settled through an accumulation of crystallographic results (3). Noteworthy among these are the neutron diffraction studies of Ibers and co-workers on $\text{HMn}(\text{CO})_5$ (4) and those of Ginsberg and co-workers on K_2ReH_9 (5). It is now known that terminal M-H distances generally lie in the range 1.5-1.7 Å, and that the hydrogen atom does exert a significant influence on the geometry of the rest of the molecule. The situation with bridging hydrogen atoms, however, is less clear. When a hydrogen atom is simultaneously bonded to two or more metal atoms, the problems involved in detecting it with X-ray data become more severe, a fact which is reflected in the relative paucity of structural results on M-H-M linkages (1). This is unfortunate because there are many things that one would like to know concerning the disposition of the hydrogen atom in these systems, such as whether the M-H-M bond is inherently linear or bent, symmetric or asymmetric.

In the past few years we have been heavily involved in the structural characterization of metal-hydrogen bonds. Early efforts were largely limited to the indirect (6) and direct (7) location of hydrogen atoms through X-ray diffraction methods, but lately we have been turning increasingly to the use of neutron diffraction, which is by far the best method for getting precise information on hydrogen positions. The sensitivity of neutron diffraction to light atoms in general and hydrogen in particular is due to the large relative cross sections of these atoms, compared to those for X-ray diffraction. For a hydride complex of a third-row transition metal, for example, the relative contribution of hydrogen is roughly three orders of magnitude greater in neutron than in X-ray diffraction. Standard deviations of metal-hydrogen bond lengths determined by neutron diffraction typically range from 0.002-0.020 Å, as opposed to 0.05-0.20 Å for X-ray methods. Balanced against these advantages is the requirement of large crystal size ($>2\text{mm}^3$), the attainment of which is usually a non-trivial matter for metal hydride complexes. Additionally, the very fact that only a few installations in the world are equipped to carry out this type of research limits the general accessibility of the technique.

* Abbreviations used in this paper are as follows: Me, methyl; Et, ethyl; *n*Bu, *n*-butyl; Ph, phenyl; Cp, cyclopentadienyl.

TERMINAL METAL-HYDROGEN (M-H) BONDS

Between 1965 and 1973, Chatt, Shaw, and their co-workers reported the synthesis of a series of very unusual covalent compounds in which several hydrogen atoms (as many as seven) are attached to a single metal atom (8):

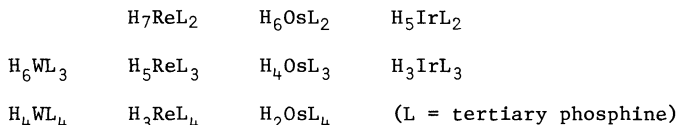

Later, Tebbe (9) and Ginsberg (10) added the complexes $H_5Ta(Me_2PCH_2CH_2PMe_2)_2$ and $[H_8Re(PR_3)]^-$ (R=Et, *n*Bu, Ph) respectively to the above list. These polyhydride complexes were found to be remarkable stable, and some were found to participate in rather spectacular H_2/D_2 exchange reactions (11). The compounds are generally colorless (or pale yellow), diamagnetic, and soluble in many organic solvents. Their structures, with a few exceptions (12), are largely unknown. The compounds exhibit interesting NMR behavior: the six-coordinate complexes are rigid, the seven- and nine-coordinate complexes are fluxional, and the eight-coordinate complexes are somewhere in between (13). Interest in the structures of polyhydride complexes is derived not only from their unusual stoichiometry, high coordination number and fluxional nature, but also from the fact that the M-H bond, which is free from π -bonding effects, is an excellent source of information from which the covalent radii of these elements can be obtained. Moreover, a detailed knowledge of the geometries of these highly hydrogenated compounds could allow one to assess how closely hydrogen atoms can pack around a single metal center.

Earlier X-ray results on $H_5Re(PPh_3)_3$, $H_3Re(Ph_2PCH_2CH_2PPh_2)_2$ and *mer*- $H_3Ir(PPh_3)_3$ by other groups indicated geometries consistent with the dodecahedron, pentagonal bipyramid and octahedron respectively (12). These investigations, together with our X-ray studies of *fac*- $H_3Ir(PMe_2Ph)_3$, $H_5Ir(PET_2Ph)_2$ and $H_7Re(PMe_2Ph)_2$ (*vide infra*), clearly revealed the metal-phosphine skeleton of the molecules but were generally unable to locate the hydrogen positions unambiguously. To date, the only neutral monomeric polyhydride complex that has been characterized by neutron diffraction is $H_4Os(PMe_2Ph)_3$ (14).

The geometry of $H_4Os(PMe_2Ph)_3$ (Fig. 1) is based on a distorted pentagonal bipyramid with two phosphine ligands in axial positions. The equatorial H_4OsP fragment (Fig. 2) is planar within $\pm 0.01\text{\AA}$. Os-H distances are 1.663(3), 1.648(3), 1.644(3) and 1.681(3) \AA , and non-bonding H...H contact distances are 1.883(5), 1.840(6) and 1.909(5) \AA . The H-Os-H angles [67.9(2), 69.4(2) and 70.0(2) $^\circ$] are somewhat compressed from the normal pentagonal value of 72 $^\circ$, due to the steric influence of the equatorial phosphine (14).

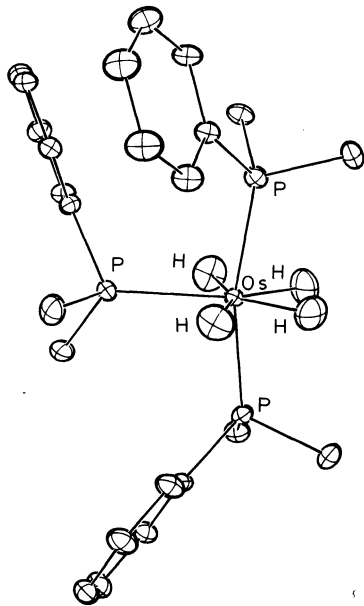

Fig. 1. The pentagonal bipyramidal geometry of $H_4Os(PMe_2Ph)_3$. Hydrogen atoms on the methyl and phenyl groups have been omitted for clarity.

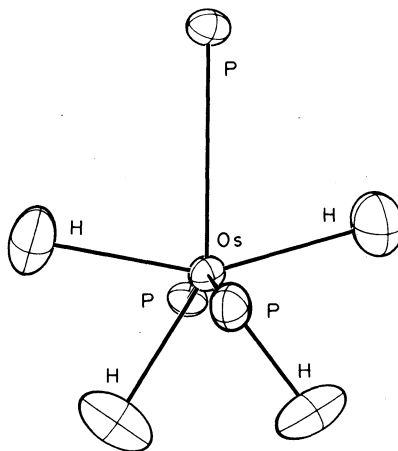
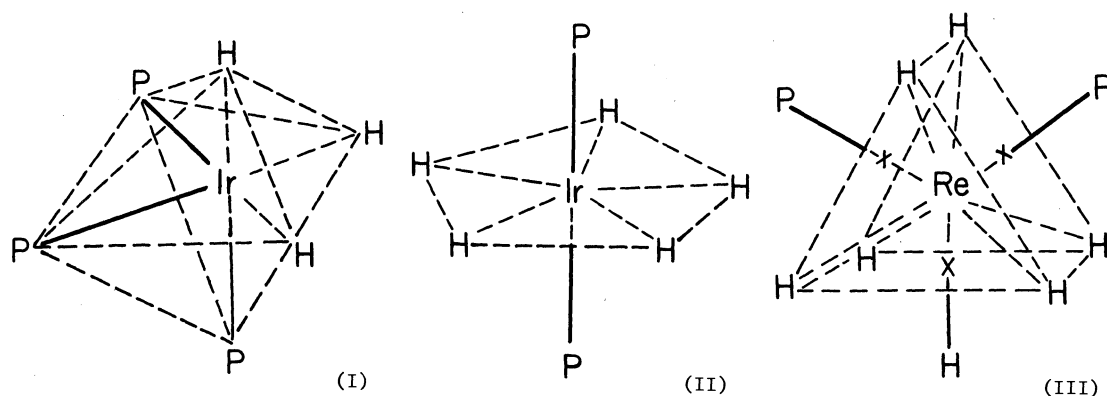

Fig. 2. The central core of the $H_4Os(PMe_2Ph)_3$ molecule, viewed normal to the H_4OsP equatorial plane.

The structure of *fac*-H₃Ir(PMe₂Ph)₃ exhibits noncrystallographic three-fold symmetry (I). Although the hydride ligands have not been located in this X-ray study, the arrangement of phosphorus atoms [Ir-P distances are 2.296(3), 2.296(3), and 2.291(3) Å; P-Ir-P angles are 101.4(1)°, 102.1(1)°, and 99.5(1)°] leaves little doubt that the geometry of the molecule is that of a trigonally distorted octahedron with a facial (*cis*) arrangement of ligands. Preliminary X-ray results on H₅Ir(PET₂Ph)₂ suggest a pentagonal bipyramidal structure (II), with a linear backbone. In contrast, an X-ray analysis of H₇Re(PMe₂Ph)₂ shows a bent P-Re-P backbone [P-Re-P=146.9(1)°, Re-P=2.396(4), 2.395(4) Å], which is consistent with a tricapped trigonal prismatic geometry (III) (15).



Gentle pyrolysis of H₇Re(PET₂Ph)₂ leads to the formation of the deep red complex H₈Re₂(PET₂Ph)₄, which is the only dimeric member of the polyhydride series known to exist. This compound was originally referred to as an "agnohydride" complex [H_xRe(PET₂Ph)₂]₂ by Chatt and Coffey (8b), who were at the time unaware of the exact number of hydride ligands in the molecule. The configuration of this compound, determined via neutron diffraction (16), is shown in Fig. 3. The molecule contains the first example of a metal-metal bond bridged by four hydrogen atoms. The coordination about each rhenium atom may be envisaged as a distorted trigonal prism (six hydrogen ligands) capped on the three square faces by two phosphine ligands and the Re-Re bond. An alternative view of the molecule is presented in Fig. 4, which shows the terminal H₂P₂ units and the bridging H₄ group in a mutually staggered arrangement.

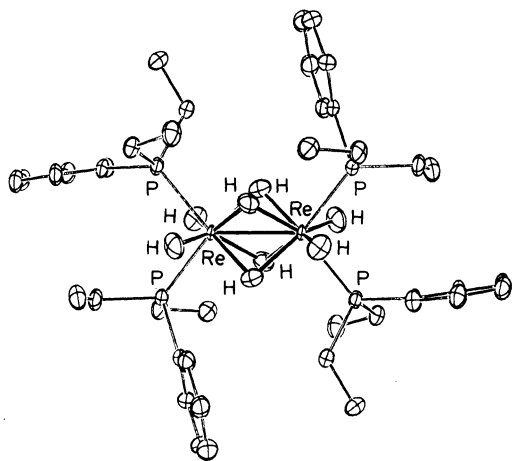

Fig. 3. The structure of H₈Re₂(PET₂Ph)₄, with H atoms of the ethyl and phenyl groups removed for clarity.

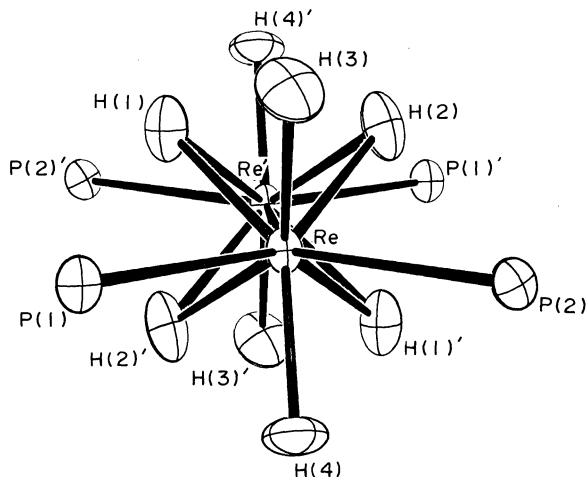

Fig. 4. The skeleton of the H₈Re₂(PET₂Ph)₄ molecule, viewed approximately along the Re-Re axis.

Terminal Re-H bond lengths in H₈Re₂(PET₂Ph)₄ [average 1.669(7) Å] agree well with those found in [ReH₉]²⁻ [1.68(1) Å] (5) and are 0.21 Å shorter than the bridging Re-H distances [average 1.878(7) Å]. This lengthening of M-H bonds from the terminal to the bridging mode has been noted previously (7a) (with increases ranging from 0.1 to 0.2 Å) but this is the first time that an accurate comparison could be made within the same molecule. The central H₄ unit is planar as required by crystallographic symmetry and defines a distorted square [H...H = 1.870(8), 2.042(8) Å] normal to the Re-Re bond (16).

The structure of H_3TaCp_2 (Fig. 5) consists of a "bent sandwich" arrangement of cyclopentadienyl rings bisected by an equatorial H_3Ta fragment (17). The hydrogen atoms are held to tantalum in a highly crowded fashion with $H-Ta = 1.769(8)$, $1.775(9)$, $1.777(9)$ Å; $H-Ta-H = 62.8(5)^\circ$, $63.0(4)^\circ$; and $H...H = 1.847(10)$, $1.855(10)$ Å. The geometry of the H_3Ta moiety, which is planar within ± 0.002 Å, resembles that of the three orbitals of the Ballhausen-Dahl model (18a) of bonding in bent sandwich complexes, and is also consistent with predictions of more recent molecular orbital treatments (18b). The acute $H-M-H$ angles and short $H...H$ contact distances found in this molecule might very well represent limits beyond which non-bonding hydrogen atoms cannot be further compressed.

It is significant to note that the trend of $M-H$ bond lengths found from the neutron diffraction analyses of $H_3Ta(C_5H_5)_2$ [$H-Ta = 1.774(3)$ Å] (17), $[ReH_9]^{2-}$ [$H-Re = 1.68(1)$ Å] (5), $H_8Re_2(PET_2Ph)_4$ [$H-Re = 1.669(7)$ Å] (16), and $H_4Os(PMe_2Ph)_3$ [$H-Os = 1.659(8)$ Å] (14) nicely follows the trend in atomic radii of these elements: Ta, 1.46; Re, 1.37; Os, 1.35. Assuming a covalent radius for hydrogen of 0.37 Å (19), the above $M-H$ distances would yield estimates of 1.40, 1.31, 1.29 Å for the covalent radii of Ta, Re, and Os respectively.

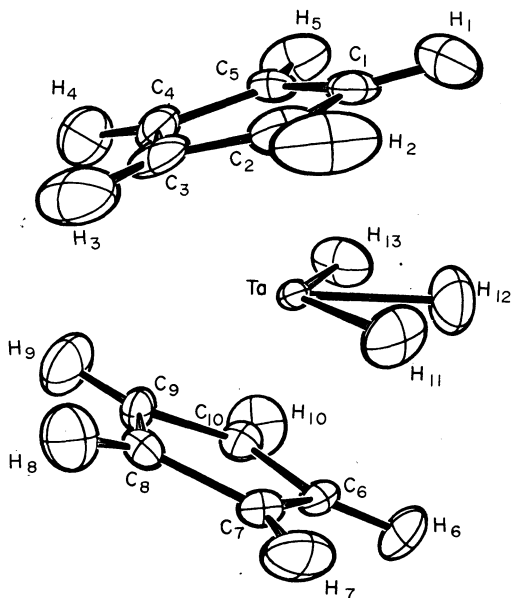

Fig. 5. The structure of H_3TaCp_2 .

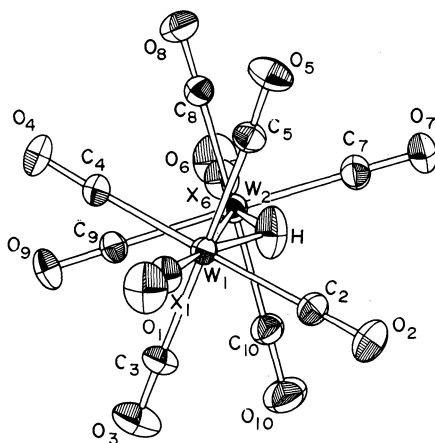

Fig. 6. The structure of $HW_2(CO)_9(NO)$.

BRIDGING METAL-HYDROGEN (M-H-M) BONDS

The $M-H-M$ bridge bond is particularly interesting to study because it is a member of a select family of bonds: electron-deficient, 3-center-2-electron bonds, of which the $B-H-B$ bridge bond is perhaps the best-known example. Unlike the $B-H-B$ bond, which is normally unsuited[†] for neutron diffraction study because of the prohibitively high neutron absorption cross section of ^{10}B , the $M-H-M$ bond poses no special difficulties as far as neutron scattering is concerned. Moreover, the characteristic octahedral coordination of many metal complexes serves as a convenient internal coordinate system to pinpoint the direction of the orbital used by the metal atom to achieve $M-H-M$ overlap, as will be evident in the following discussion.

Our first neutron diffraction analysis, carried out in collaboration with Prof. S. W. Kirtley of New College, was on the structure of $HW_2(CO)_9(NO)$. Prior X-ray work (20) had established a bent backbone for the molecule, and it was considered reasonable to assume that the bridging hydrogen atom, which was not located in the X-ray study, would be situated at the point of intersection of the two axial ligand-tungsten vectors (IV). Instead, the neutron results (21) (Fig. 6) showed that the hydrogen atom was significantly removed from the predicted position: The axial ligand tungsten vectors were found to point not at the hydrogen atom but approximately at the center of the WHW triangle (V).

[†] An exception is the neutron diffraction analysis of $B_{10}H_{14}$, which was carried out on a ^{11}B -enriched sample [A. Tippe and W. C. Hamilton, *Inorg. Chem.*, **8**, 464 (1969)].

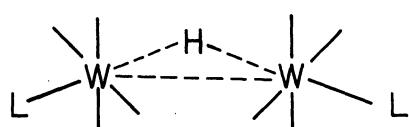

(IV)

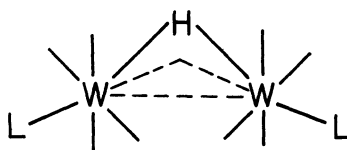

(V)

This unexpected finding provided evidence that the nature of the overlap in a bent M-H-M bond is "closed" (VI) (i.e., contains substantial metal-metal bonding character) rather than "open" (VII). In analogy with standard notation used in boron hydride chemistry, the formalism (VIII) was suggested to represent this type of 3-center-2-electron bond (21). A consequence of the "closed" formalism is that, since metal-metal bonding is actually an integral part of the M-H-M bridge bond, the concept of bond order for a metal-metal bond bridged by one or more hydrogen atoms becomes somewhat ambiguous.

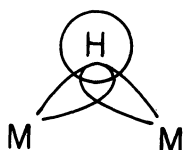

(VI)

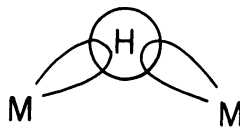

(VII)

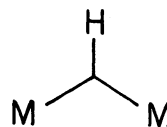

(VIII)

We originally hoped to find an asymmetric M-H-M bond in $\text{HW}_2(\text{CO})_9(\text{NO})$, a reasonable expectation since the two halves of the molecule, $\text{W}(\text{CO})_5$ and $\text{W}(\text{CO})_4(\text{NO})$, have different electronic requirements. However, a 50%:50% nitrosyl-carbonyl packing disorder (21) generated the appearance of a symmetrical M-H-M bond (IX):

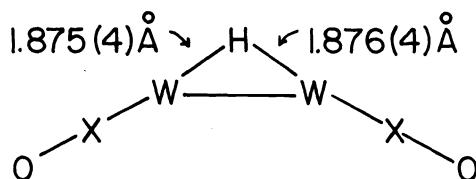

(IX)

X=50%N; 50%C

To circumvent this problem, the derivative $\text{HW}_2(\text{CO})_8(\text{NO})(\text{P}(\text{OMe})_3)$ was prepared with the idea that the bulk of the phosphite ligand would prevent such packing disorder from taking place. The neutron diffraction analysis of this compound (22) (Fig. 7) did reveal an asymmetric M-H-M linkage (X), but the degree of asymmetry was quite small. This fact suggests that M-H-M bonds (and, by implication, other 3-center-2-electron bonds) probably cannot deviate very much from a truly symmetric condition, in contrast to common hydrogen bonds (such as O-H...O) which of course can be markedly asymmetric (23).

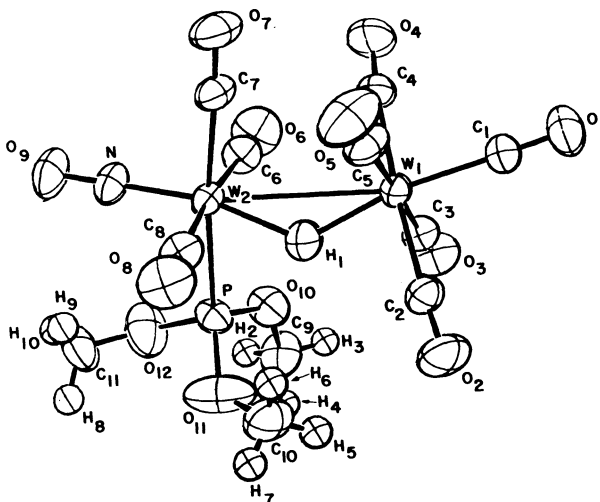
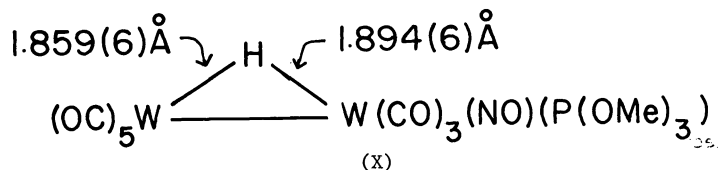

Fig. 7. The structure of $\text{HW}_2(\text{CO})_8(\text{NO})(\text{P}(\text{OMe})_3)$.



When the structure of $\text{HW}_2(\text{CO})_9(\text{NO})$ became known, attention was shifted to its precursor, the isoelectronic $[\text{HW}_2(\text{CO})_{10}]^-$ ion. Earlier, Dahl and co-workers had shown with X-ray techniques that the $[\text{HCr}_2(\text{CO})_{10}]^-$ anion in $[\text{Et}_4\text{N}]^+[\text{HCr}_2(\text{CO})_{10}]^-$ had D_{4h} symmetry, with a linear backbone and eclipsed carbonyl groups (24). It was generally assumed that the analogous $[\text{HW}_2(\text{CO})_{10}]^-$ anion would be isostructural with the chromium species, but the bent and staggered geometry of $\text{HW}_2(\text{CO})_9(\text{NO})$ (Fig. 6) now cast some doubt on this assumption. Accordingly, the X-ray structure determination of $[\text{HW}_2(\text{CO})_{10}]^-$ was carried out, with very surprising results (25). The anion turned out to have two different structures, depending on the cation used! With $[(\text{Ph}_3\text{P})_2\text{N}]^+$, it adopts a bent structure (Fig. 8) much like the isoelectronic $\text{HW}_2(\text{CO})_9(\text{NO})$, while with $[\text{Et}_4\text{N}]^+$ it appeared to adopt a D_{4h} structure with a linear backbone (Fig. 9), just as in $[\text{HCr}_2(\text{CO})_{10}]^-$. The very existence of two forms of $[\text{HW}_2(\text{CO})_{10}]^-$ in the solid state shows that the M-H-M linkage is a flexible, easily deformable entity.

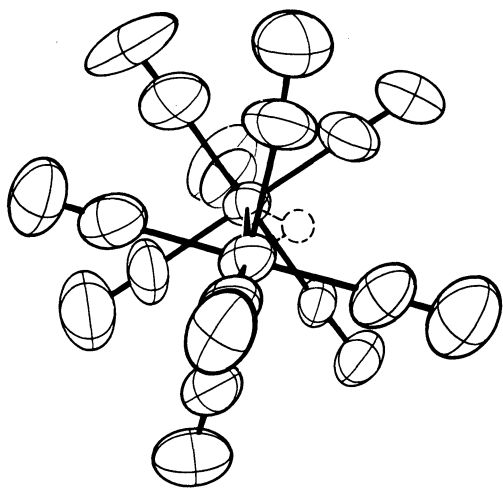

Fig. 8. Bent form of the $[\text{HW}_2(\text{CO})_{10}]^-$ anion in $[(\text{Ph}_3\text{P})_2\text{N}]^+[\text{HW}_2(\text{CO})_{10}]^-$, as determined by X-ray diffraction. The H position is assumed.

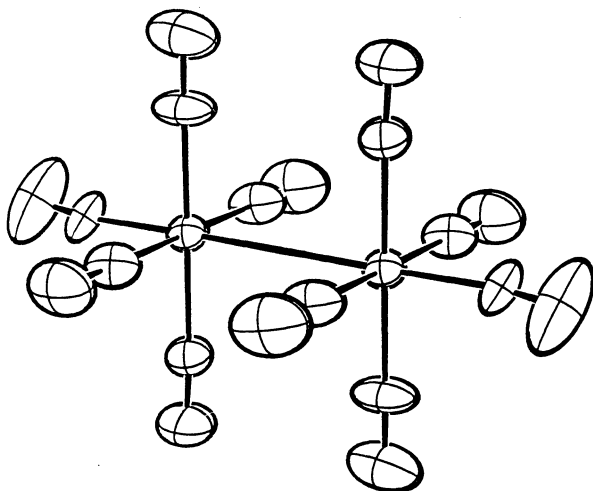
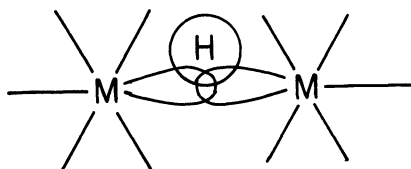

Fig. 9. Linear form of the $[\text{HW}_2(\text{CO})_{10}]^-$ anion in $[\text{Et}_4\text{N}]^+[\text{HW}_2(\text{CO})_{10}]^-$, as determined by X-ray diffraction. The H atom, which is not indicated in this diagram, was later shown by neutron diffraction to be displaced off the main W-W axis of the molecule (see text).

Recently, a refinement of the structure of $[\text{Et}_4\text{N}]^+[\text{HCr}_2(\text{CO})_{10}]^-$ based on neutron diffraction data has been carried out by Dahl, Williams and co-workers (26). Their results revealed that, contrary to earlier assumptions (24), the central Cr-H-Cr bond in the anion is not linear but bent (XI).



(XI)

We have recently collected low temperature neutron diffraction data (14 K) on the isomorphous $[\text{Et}_4\text{N}]^+[\text{HW}_2(\text{CO})_{10}]^-$ and have confirmed the off-axis location of the hydrogen atom (26). The hydrogen atom in $[\text{Et}_4\text{N}]^+[\text{HW}_2(\text{CO})_{10}]^-$ is located 0.71\AA off the center of the W-W bond and the W-H distance is 1.89\AA . There is distinct evidence of disorder in the carbonyl groups, indicating that the "linear" structure (Fig. 9), ostensibly D_{4h} , is in fact a superposition of two or more slightly bent forms.

The evidence accumulated thus far strongly suggests that there may in fact be no such thing as a linear M-H-M bond. In other words, the results described here constitute experimental evidence that the electron-deficient 3-center-2-electron bond is by its very nature inherently bent.

A qualitative molecular orbital argument can be put forward regarding this point. Figure 10 compares the linear $[F-H-F]^-$ bond ($3c, 4e^-$) with the bent M-H-M bond ($3c, 2e^-$).

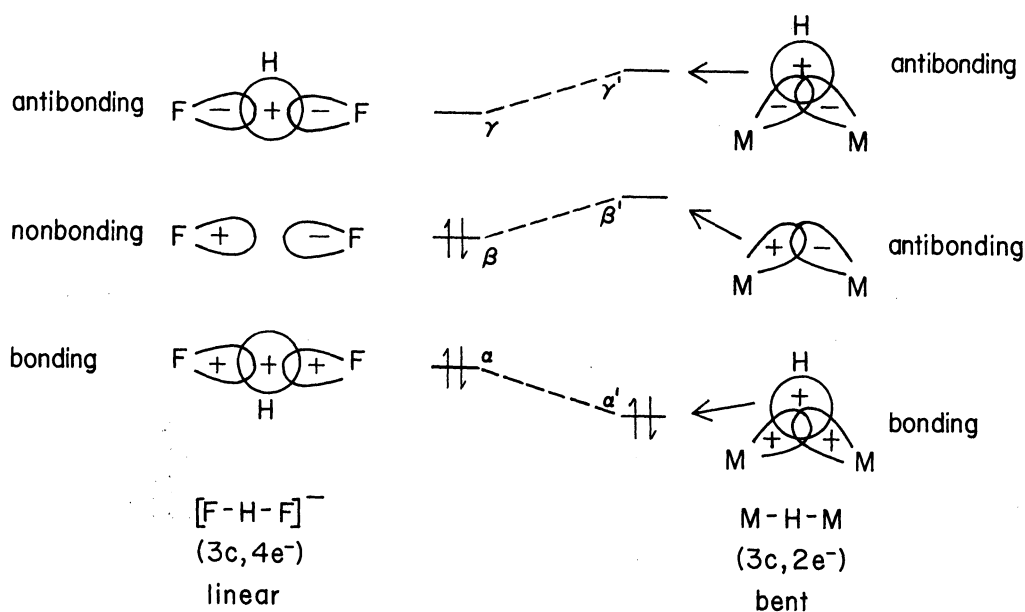

Fig. 10. A schematic comparison between the overlap patterns of linear ($3c, 4e^-$) and bent ($3c, 2e^-$) X-H-X systems.

If one accepts the fact that there is significant M-M overlap in a M-H-M bond, one can appreciate that the mid-energy orbital, which is non-bonding (β) in the $[F-H-F]^-$ case, is antibonding (β') in the M-H-M case. One can then argue that the M-H-M system would prefer to remain bent, and not acquire an additional two electrons into this energetically unfavorable (β') orbital. If forced to do so, the M-H-M system would revert into a linear ($3c, 4e^-$) configuration which is most likely unstable with respect to dissociation into (M-H + M) fragments. The crux of the argument is that, as long as there is significant M-M overlap, the $2e^-$ bond will bend, allowing closer M-M approach. It has been pointed out to us (27) that the situation represented by Fig. 10 is not unlike the H_3 system, which in the two-electron case (H_3^+) exists as a stable equilateral triangle, but in the four-electron case (H_3^-) is not bound with respect to ($H_2 + H^-$). The H_3^- system, although unstable, at any distance prefers a linear geometry over a bent one.

TRIPLY-BRIDGING METAL-HYDROGEN [$(\mu^3-H)M_3$] BONDS

A hydrogen atom covalently bonded simultaneously to three other atoms is rarely found. To our knowledge, in molecular species this type of linkage has been definitively characterized only in metal cluster complexes. In principle, a hydrogen atom can attach itself to a metal cluster in several ways: by forming a terminal M-H bond, an edge-bridging M-H-M bond, a face-bridging (or triply-bridging) M_3H bond, or by being embedded in an interstitial position (i.e., inside the metal cluster). Examples of all these bonding modes have now been found.

The hydrogen atom in $HFeCo_3(CO)_{12}$ was at one time thought to be in an interstitial position. Mass spectral investigations, inelastic neutron scattering experiments and other spectral studies suggested the hydrogen atom to be in the center of the $FeCo_3$ tetrahedron (28). This model was disproved in 1975 when an X-ray structural investigation of the tris (trimethylphosphite) derivative by Kaesz and co-workers (29) unambiguously located the hydrogen atom outside the metal tetrahedron, capping the Co_3 face. The accuracy of the hydrogen position was substantially improved by a subsequent neutron diffraction study, in which the Co-H distances were determined to be 1.742(3), 1.731(3) and 1.728(3) Å, the displacement of the hydrogen atom from the Co_3 plane was found to be 0.978(3) Å (Fig. 11) (30).

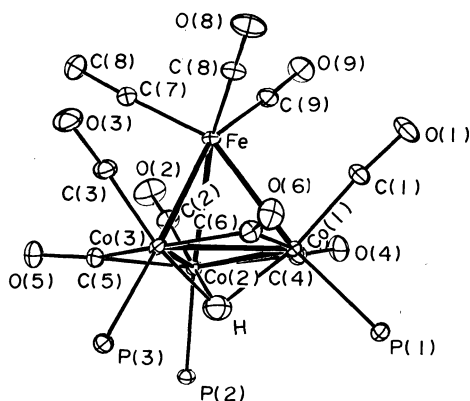

Fig. 11. The structure of $\text{HFeCo}_3(\text{CO})_9(\text{P}(\text{OMe})_3)_3$, with methoxy groups removed for clarity,

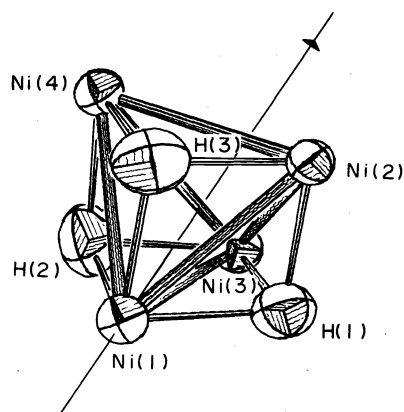

Fig. 12. The central H_3Ni_4 core of the $\text{H}_3\text{Ni}_4\text{Cp}_4$ molecule.

Another face-bridging hydride cluster investigated by neutron diffraction methods is $\text{H}_3\text{Ni}_4\text{Cp}_4$. Earlier X-ray work on this compound by Huttner and co-workers placed the hydrogen atoms on three of the four faces of the tetrahedron (31). Although the hydrogen atoms were not located in this X-ray study, a distortion of the arrangement of cyclopentadienyl rings about the Ni_4 tetrahedron to produce C_{3v} symmetry suggested the model described above. A recently completed neutron diffraction study (30) has confirmed this model (Fig. 12) and has given the following average molecular parameters: $\text{Ni-H} = 1.691(8)$ Å, $\text{Ni-Ni} = 2.469(6)$ Å, $\text{H}\dots\text{H} = 2.316(6)$ Å, $\text{Ni-H-Ni} = 93.9(3)^\circ$, $\text{H-Ni-H} = 86.1(6)^\circ$. The H_3Ni_4 core of the molecule resembles a cube with one vacant corner. The hydrogen atoms are displaced by an average of $0.91(1)$ Å from the planes of the nickel atoms.

One rationale for studying the structures of metal hydride cluster complexes is that the configuration of hydrogen atoms in these clusters may serve as a good model for studying the arrangement of hydrogen atoms adsorbed on a metal surface. It is generally agreed that chemisorbed hydrogen in an activated metal catalyst is in the dissociated (monatomic) form. Since the Co-Co and Ni-Ni distances in $\text{HFeCo}_3(\text{CO})_9(\text{P}(\text{OMe})_3)_3$ and $\text{H}_3\text{Ni}_4\text{Cp}_4$ (30) are very close to those in cobalt and nickel metal respectively (32), one can postulate that the arrangement of hydrogen atoms on a cobalt or nickel surface might be expected to adopt dimensions similar to those of the HCo_3 and HNi_3 fragments in the above molecules.

Although the existence of interstitial hydrogen atoms has so far not been proven in any tetrahedral metal cluster, they have been characterized in octahedral metal clusters. Powder neutron diffraction work by Simon on $\text{H}\text{Nb}_6\text{I}_{11}$ indicated the presence of hydrogen atoms in the centers of the Nb_6 octahedra (33). More recently, single-crystal neutron diffraction studies by Chini, Dahl, Williams and their colleagues (34) on the $[\text{HNi}_{12}(\text{CO})_{21}]^{3-}$ and $[\text{H}_2\text{Ni}_{12}(\text{CO})_{21}]^{2-}$ anions have definitively shown the existence of hydrogen atoms inside the octahedral holes of these Ni_{12} clusters. It was found that there is more than enough room within a Ni_6 octahedron to accommodate a hydrogen atom, with sufficient clearance for the hydrogen to "rattle around" in its metal cage (34). A tetrahedral metal cluster has of course much less room in its interior, and it is not clear at this point if a hydrogen atom could be comfortably accommodated within such a cluster without causing appreciable "swelling" of the M_4 framework.

Acknowledgements - We wish to thank our many collaborators in this project for their fine efforts; L.C. Andrews, W.E. Carroll, H.B. Chin, D.W. Hart, Å. Kvik, R.A. Love, R.K. McMullan, J.P. Olsen, R.G. Teller, D.L. Tipton, G.J.B. Williams and R.D. Wilson. Special thanks go to Prof. S.W. Kirtley, without whose help much of the early work on W-H-W systems could never have taken place. We also acknowledge the generosity of Prof. H.D. Kaesz, Prof. J. Müller, Dr. G.W. Parshall and Dr. F.N. Tebbe for the samples of $\text{HFeCo}_3(\text{CO})_9(\text{P}(\text{O}(\text{Me})_3)_3)_3$, $\text{H}_3\text{Ni}_4\text{Cp}_4$ and H_3TaCp_2 used in this work, and valuable discussions with Prof. R. Hoffmann and Dr. M. Newton. Technical assistance in operating the neutron diffractometer was provided by Mr. J. Henriques. Research at Brookhaven National Laboratory was performed under contract with the U.S. Energy Research and Development Administration and supported by its Division of Basic Energy Sciences. Research at the University of Southern California was supported by National Science Foundation Grants CHE-74-01541 and CHE-77-00360, the Petroleum Research Fund Grants 7800-AC3,6 and 9688-AC3,6 (administered by the American Chemical Society). R.B. acknowledges the receipt of an Alfred P. Sloan Fellowship (1974-76) and an NIH Research Career Development Award (1975-80) during the course of this work.

REFERENCES

1. R.B. Saillant and H.D. Kaesz, Chem. Revs., **72**, 231 (1972).
2. A.P. Ginsberg, Transition Metal Chemistry, **1**, 112 (1968).
3. B.A. Frenz and J.A. Ibers, in "Transition Metal Hydrides", E.L. Muetterties, ed., Marcel Dekker, New York, (1971); page 33.
4. S.J. LaPlaca, W.C. Hamilton, J.A. Ibers, and A. Davison, Inorg. Chem., **8**, 1928 (1969).
5. S.C. Abrahams, A.P. Ginsberg, and K. Knox, Inorg. Chem., **3**, 558 (1964).
6. a. H.D. Kaesz, R. Bau, and M.R. Churchill, J. Amer. Chem. Soc., **89**, 2775 (1967).
b. M.R. Churchill and R. Bau, Inorg. Chem., **6**, 2986 (1967).
c. M.R. Churchill, P.H. Bird, H.D. Kaesz, R. Bau, and B. Fontal, J. Amer. Chem. Soc., **90**, 7135 (1968).
d. H.D. Kaesz, B. Fontal, R. Bau, S.W. Kirtley, and M.R. Churchill, J. Amer. Chem. Soc., **91**, 1021 (1969).
7. a. S.W. Kirley, J.P. Olsen, and R. Bau, J. Amer. Chem. Soc., **95**, 4532 (1973).
b. M.B. Smith and R. Bau, J. Amer. Chem. Soc., **95**, 5068 (1973).
c. R. Bau, B. Don, R. Greatrex, R.J. Haines, R.A. Love, and R.D. Wilson, Inorg. Chem., **14**, 3021 (1975).
8. a. J. Chatt, R.S. Coffey, and B.L. Shaw, J. Chem. Soc., 7391 (1965).
b. J. Chatt and R.S. Coffey, J. Chem. Soc. (A), 1963 (1969).
c. P.G. Douglas and B.L. Shaw, J. Chem. Soc. (A), 334 (1970).
d. J.R. Moss and B.L. Shaw, J. Chem. Soc. Dalton, 1910 (1972).
e. B. Bell, J. Chatt, and G.J. Leigh, J. Chem. Soc. Dalton, 997 (1973).
9. F.N. Tebbe, J. Amer. Chem. Soc., **95**, 5823 (1973).
10. A.P. Ginsberg, Chem. Commun., 857 (1968).
11. E.K. Barefield, G.W. Parshall, and F.N. Tebbe, J. Amer. Chem. Soc., **92**, 5234 (1970).
12. a. A.P. Ginsberg, S.C. Abrahams, and P.B. Jamieson, J. Amer. Chem. Soc., **95**, 4751 (1973).
b. V.G. Albano and P. Bellon, J. Organometal. Chem., **37**, 151 (1972).
c. G.R. Clark, B.W. Skelton, and T.N. Waters, Inorg. Chim. Acta, **12**, 235 (1975).
13. a. J.P. Jesson, in "Transition Metal Hydrides", E.L. Muetterties, ed., Marcel Dekker, New York, N.Y., 1971, page 75.
b. P. Meakin, L.J. Guggenberger, E.L. Muetterties, and J.P. Jesson, J. Amer. Chem. Soc., **95**, 1467 (1973).
14. D.W. Hart, R. Bau, and T.F. Koetzle, J. Amer. Chem. Soc., in press (1977).
15. R. Bau, W.E. Carroll, D.W. Hart, R.G. Teller, and T.F. Koetzle, Adv. Chem. Ser., in press (1978).
16. R. Bau, W.E. Carroll, R.G. Teller, and T.F. Koetzle, J. Amer. Chem. Soc., **99**, 3872 (1977).
17. R.D. Wilson, T.F. Koetzle, D.W. Hart, Å. Kvik, D.L. Tipton, and R. Bau, J. Amer. Chem. Soc., **99**, 1775 (1977).
18. a. C.J. Ballhausen and J.P. Dahl, Acta Chem. Scand., **15**, 1333 (1961).
b. J.W. Lauher and R. Hoffmann, J. Amer. Chem. Soc., **98**, 1729 (1976).
19. "Tables of Interatomic Distances and Configurations in Molecules and Ions", Special Publication #18, The Chemical Society (London), 1965, page S6s.
20. M. Andrews, D.L. Tipton, S.W. Kirtley, and R. Bau, Chem. Commun., 181 (1973).
21. J.P. Olsen, T.F. Koetzle, S.W. Kirtley, M.A. Andrews, D.L. Tipton, and R. Bau, J. Amer. Chem. Soc., **96**, 6621 (1974).
22. R.A. Love, H.B. Chin, T.F. Koetzle, S.W. Kirtley, B.R. Whittlesey, and R. Bau, J. Amer. Chem. Soc., **98**, 4491 (1976).
23. W.C. Hamilton and J.A. Ibers, "Hydrogen Bonding in Solids", W.A. Benjamin, N.Y., (1968).
24. a. L.B. Handy, P.M. Treichel, L.F. Dahl, and R.G. Hayter, J. Amer. Chem. Soc., **88**, 366 (1966).
b. L.B. Handy, J.K. Ruff, and L.F. Dahl, J. Amer. Chem. Soc., **92**, 7312 (1970).
25. R.D. Wilson, S.A. Graham, and R. Bau, J. Organometal. Chem., **91**, C49 (1975).

26. J. Roziere, J.M. Williams, R.P. Stewart, J.L. Petersen, and L.F. Dahl, J. Amer. Chem. Soc., 99, 4497 (1977).
27. R. Hoffmann, private communication.
28. a. M.J. Mays and R.N.F. Simpson, J. Chem. Soc. (A), 1444 (1968).
b. J.W. White and C.J. Wright, J. Chem. Soc. (A), 2843 (1971).
c. C.E. Cooke and M.J. Mays, J. Chem. Soc., Dalton, 455 (1975).
29. B.T. Huie, C.B. Knobler, and H.D. Kaesz, Chem. Commun., 684 (1975).
30. T.F. Koetzle, R.K. McMullan, R. Bau, D.W. Hart, R.G. Teller, D.L. Tipton, and R.D. Wilson, Adv. Chem. Ser., in press (1978).
31. a. J. Müller, H. Dorner, G. Huttner, and H. Lorenz, Angew. Chem. Internat. Edit., 12, 1005 (1973).
b. G. Huttner and H. Lorenz, Chem. Ber., 107, 996 (1974).
32. a. F. Vincent and M. Figlarz, C.R. Acad. Sci., Paris, Ser., 264, 1270 (1967).
b. T.R. Anantharaman, Current Sci., India, 27, 51 (1958).
33. A. Simon, Z. Anorg. Allgem. Chem., 355, 311 (1967).
34. L.F. Dahl, R.W. Broach, J.M. Williams, G. Longoni, and P. Chini, Adv. Chem. Ser., in press (1978).