

Stereospecific synthesis of olefins through sequential cross-coupling reactions

Francesco Naso

Centro CNR Metodologie Innovative di Sintesi Organiche, Dipartimento di Chimica, Università di Bari, Via Amendola 173, 70126 Bari, Italy.

Abstract - A conceptually straightforward and useful procedure leading to (*Z*)- or (*E*)-olefins is presented. The method is based upon the reaction of the readily available (*Z*)- or (*E*)-1-bromo-2-phenylthioethene (1 or 2) with Grignard reagents in the presence of Ni(II) or Pd(II) catalysts. Other catalysts, e.g. iron(III) derivatives, and other organometallics, e.g. zinc reagents or copper derivatives, can also be successfully used during the substitution of the halogen. The stereospecificity is $\geq 99\%$ in the case of (*E*)-isomers and slightly lower in the case of (*Z*)-isomers. Enantioselectivity is achieved by using chiral ligands. By appropriate choice of the reagent, alkyl- or aryl-substituted ethenes, 1,3- or 1,6-dienes, and conjugated enynes can be prepared. Allyl and alkadienyl silanes can also be obtained. The reaction of the latter compounds with palladium chloride leads to conjugated tetraenes. Dienyl bromides or ketones are prepared by reaction of the same compounds with aluminum chloride and cyanogen bromide or acyl chloride respectively. The versatility of this method has been demonstrated by the stereospecific synthesis of insect pheromones and a number of key synthetic intermediates.

INTRODUCTION

The cross-coupling reaction between alkenyl halides and organometallics represents a process of special synthetic value, as it enables the stereodefined production of a variety of systems with a carbon-carbon double bond. A host of organometallic reagents can be used, but organocopper derivatives (refs. 1,2) or Grignard reagents (the latter in the presence of transition metal complexes) (refs. 2,3) appear to be as the most versatile. We performed an investigation with the aim of uncovering the basic mechanistic features of the reaction with organocopper reagents (ref. 4). Two types of systems were studied: (*Z*)- and (*E*)-1-halogeno-2-phenylethenes and 1-halogeno-2-phenylsulphonylenes. The two systems showed a different behaviour. A stereochemical pathway of retention of configuration was observed for the styrene system, whereas a variable stereochemical course depending upon the configuration of the substrate, the nature of the leaving group, and the type of cuprate was valid for the sulphones. Furthermore, a marked leaving group effect ($\text{Br} > \text{Cl} > \text{F}$) was observed for the first system whereas the halogeno-sulphones were found to be much less sensitive to the change of the leaving group ($\text{Br} \sim \text{Cl} \sim \text{F}$). These and other results were explained in terms of two main mechanistic pathways with blurred boundaries: a concerted substitution of the halogen should occur in the styrene system whereas the halogeno-sulphones should follow the more common addition-elimination mechanism (ref. 5).

On the synthetic side, an important result of our analysis is that caution has to be used in regarding the reactions of vinyl halides with cuprates as stereospecific when activated systems are used. Furthermore, during our investigation we took advantage of the reactivity of sulphonylenes in addition reactions of cuprates (ref. 6), by setting up a highly stereoselective procedure leading to (*Z*)-olefins (ref. 7). The method is based upon the addition of (*Z*)-dialkenyl cuprates generated as described by Normant (ref. 8) to α,β -unsaturated sulphones to give products in which the (*Z*)-geometry of the cuprate alkenyl group is maintained. Desulphonylation of the resulting β,γ -unsaturated sulphones leads to the final olefin. The overall yields of this novel olefin synthesis are in the range 70-80% and the stereoselectivity is higher than 99% (Scheme 1).

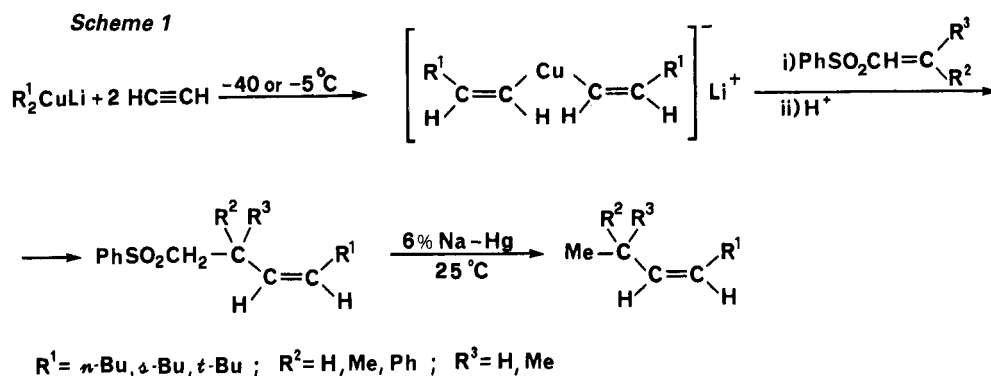

The work presented above stimulated our interest in the synthesis of symmetric and non-symmetric 1,2-disubstituted ethenes. Many procedures exist for the preparation of these compounds. However, the task becomes much more difficult when stereoselectivity is required. We reasoned that a simple synthesis of both (*E*)- and (*Z*)-isomers of 1,2-dialkyl- and diaryl-ethenes could be based on sequential formation of two C-C bonds which should occur when ethenes bearing two different leaving groups (LG) are reacted with suitable organometallic reagents according to Scheme 2:

Scheme 2

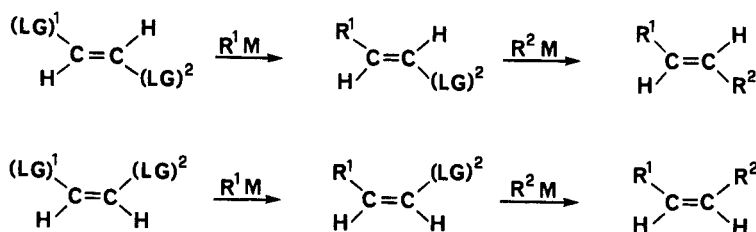

After some exploratory work, the substrates of choice appeared to be (*Z*)- and (*E*)-1-bromo-2-phenylthioethenes **1** and **2**. These compounds can easily be prepared according to the procedure of Montanari (ref. 9) by nucleophilic addition of PhSH to propiolic acid in ethanol and subsequent one pot bromine addition and decarboxylative dehalogenation to give **1** and **2** in ca 4:1 ratio. The two isomers can be separated by distillation.

SEQUENTIAL CROSS-COUPLING REACTIONS OF GRIGNARD REAGENTS WITH 1-BROMO-2-PHENYLTHIOETHENES IN THE PRESENCE OF Ni OR Pd CATALYSTS: A STEREOSPECIFIC ROUTE TO OLEFINS

Compounds **1** and **2** were found to react smoothly with Grignard reagents in the presence of a Ni(II) or Pd(II) complex as a catalyst according to Scheme 3 (ref.10).

Scheme 3

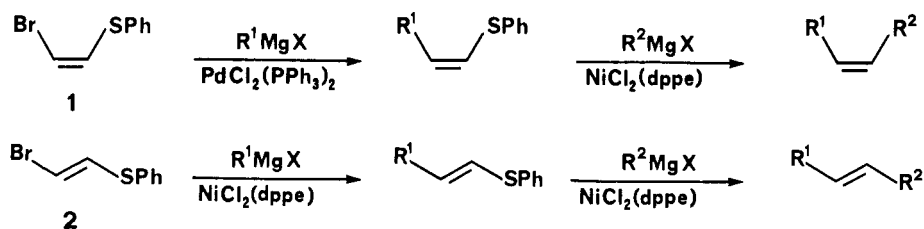

dppe = Ph₂PCH₂CH₂PPh₂

R¹, R² = alkyl or aryl

In the first step, substitution of the halogen atom occurs at a rate which is sufficiently fast to leave the carbon-sulphur bond completely unaffected. The slower reaction leading to the substitution of the phenylthio-group can be performed using longer reaction times and an excess of Grignard reagent. In order to prepare non-symmetrical olefins, it is necessary to use a different Grignard reagent after completion of the first step. The isomeric purity of the final product is higher than 99% in the case of (*E*)-isomers and slightly lower for the (*Z*)-isomers. In several reactions it was found that the use of a Pd catalyst in the first step of the sequence leading to (*Z*)-isomers gives better stereochemical results. However, Ni catalysts cannot be replaced by Pd catalysts in the second step. Often, it is not necessary to isolate the vinyl sulphide intermediate and the procedure can be performed successfully in one pot. The reactions are carried out at room temperature in ether or THF.

Secondary \rightarrow primary group isomerization is known to occur frequently in cross-coupling reactions involving simple alkyl groups such as isopropyl or *sec*-butyl groups. Therefore, in order to extend the potential of our olefin synthesis, we undertook a detailed investigation of our cross-coupling reactions with secondary reagents (ref. 11). In particular, since Ni catalysts are required in the second step whereas a variety of catalysts can be used in the first step, we focused our attention on the substitution of the halogen atom. It is noteworthy that this reaction provides a convenient route to alkenyl sulphides, a class of synthetically important compounds. Therefore, besides representing a crucial step of our procedure, the substitution of the bromine atom is also important in itself. The results of our investigation showed that the reactions of (*Z*)-1-bromo-2-phenylthioethene with isopropyl magnesium chloride in ether or THF and in the presence of $\text{PdCl}_2(\text{PPh}_3)_2$ give a relatively large amount (32-66%) of product derived from *sec*-alkyl \rightarrow *n*-alkyl isomerization. The use of $\text{PdCl}_2(\text{dppf})$ [dppf = 1,1'-bis(diphenylphosphino)ferrocene] or $\text{NiCl}_2(\text{dppe})$ reduces the extent of isomerization to small values ($\leq 6\%$) independently from the configuration of the starting material. The reactions with *sec*-butylmagnesium chloride are not influenced to a significant extent by isomerization. The cross-coupling process is efficiently catalyzed by iron(III) compounds such as FeCl_3 , $\text{Fe}(\text{acac})_3$ (acac = acetylacetonide), $\text{Fe}(\text{DBM})_3$ (DBM = dibenzoylmethide) and $\text{Fe}(\text{DPM})_3$ (DPM = dipivaloylmethide). Furthermore, the isomerization is completely suppressed by using $\text{Fe}(\text{DBM})_3$ or $\text{Fe}(\text{DPM})_3$ as a catalyst. As observed with other catalysts, the degree of retention of configuration is high.

Work is in progress in order to evaluate the possibility of achieving an enantioselective synthesis of 1,2-disubstituted olefins with one or two chiral centres using chiral complexes as catalysts (ref. 12). So far, only the first cross-coupling step has been subjected to scrutiny (ref. 13) and the preliminary data obtained are reported in Table 1.

TABLE 1

$$\text{Br}-\text{CH}=\text{CH}-\text{SPh} \xrightarrow[\text{cat.}]{\text{R}^1\text{R}^2\text{CHMgX}} \text{R}^1\text{R}^2\text{CH}-\text{CH}=\text{CH}-\text{SPh}$$

Entry	Substrate	$\text{R}^1\text{R}^2\text{CHMgX}$	Product	Yield%	Optical yield %
1) ^a				50	55
2) ^b				70	51
3) ^a				78	52

^a cat. = PdCl_2 [(*S*)-(R)-PPFA]; ^b cat. = NiCl_2 [(*S*)-(R)-PPFA]

[(*S*)-(R)-PPFA] = (*S*)-N,N-dimethyl-1-[(R)-2-(diphenylphosphino)ferrocenyl]ethylamine

It is noteworthy that the olefins prepared are synthetically useful intermediates. Indeed, as in similar cases (ref. 12), (*Z*)-3-phenyl-but-1-en-1-yl phenyl sulphide was oxidized to 2-phenylpropionic acid, a member of a family of well known anti-inflammatory agents (Ibuprofen, Naproxen, etc.). Furthermore, the same compound was transformed into optically active 3-phenylbutanal by adding HCl and treating with HgCl₂. Entry 3 represents an example taken from a wider investigation (ref. 14) which showed the possibility of obtaining (*Z*)- or (*E*)-allylsilanes starting from compounds 1 or 2.

SYNTHESIS OF MONO-OLEFINIC INSECT PHEROMONES OF (*Z*)- OR (*E*)- CONFIGURATION

Insect sex pheromones have become a veritable training ground on which to test the utility of novel synthetic methodology. Therefore, we used our procedure to prepare a variety of pheromone components or their isomeric counterparts (ref. 15). Scheme 4 summarizes the synthesis of two mono-olefinic insect pheromones components and one precursor. The overall isolated yields were in the range 65-75% and the isomeric purities were higher than 98%.

Scheme 4

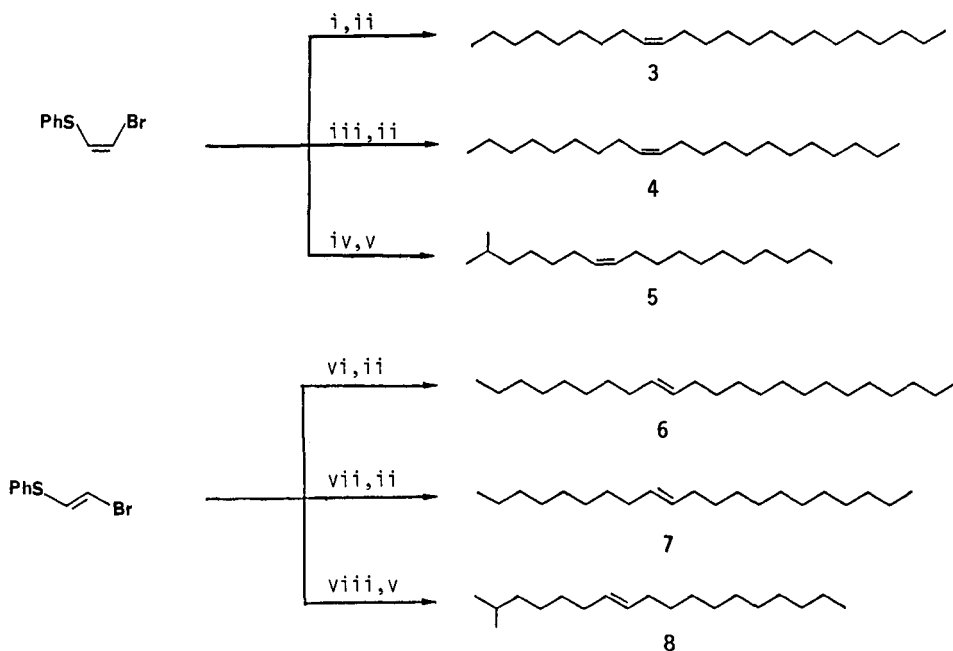

Reagents: i, $\underline{n-C}_{13}H_{27}MgBr$, $PdCl_2(PPh_3)_2$; ii, $\underline{n-C}_8H_{17}MgBr$, $NiCl_2(dppe)$; iii, $\underline{n-C}_{11}H_{23}MgBr$, $PdCl_2(PPh_3)_2$; iv, $\underline{n-C}_{10}H_{21}MgBr$, $PdCl_2(PPh_3)_2$; v, $(CH_3)_2CH(CH_2)_4MgBr$, $NiCl_2(dppe)$; vi, $\underline{n-C}_{13}H_{27}MgBr$, $NiCl_2(dppe)$; vii, $\underline{n-C}_{11}H_{23}MgBr$, $NiCl_2(dppe)$; viii, $\underline{n-C}_{10}H_{21}MgBr$, $NiCl_2(dppe)$.

(*Z*)-Tricos-9-ene 3 (muscalure) is the sex pheromone of the housefly (*Musca domestica*) whereas the effectiveness of (*Z*)-heneicos-9-ene 4 when mixed with 3 is rather controversial. (*Z*)-2-methyl-octadec-7-ene 5 upon oxidation gives (*Z*)-7,8-epoxy-2-methyl octadecane (disparlure) the sex pheromone of the gipsy moth (*Porthetria dispar*). The synthesis of the corresponding stereoisomers was easily accomplished starting with (*E*)-1-bromo-2-phenylthioethene with overall isolated yields in the range 85-90% and isomeric purities higher than 99%. In the case of both types of isomers, isolation of the alkenyl sulphides intermediates was not required and the Grignard reagent for the second cross-coupling reaction was added directly to the reaction mixture.

As reported in Scheme 5, the procedure was extended to the synthesis of pheromones having an alkenyl acetate structure. Grignard reagents obtained from 1-halogeno- ω -tetrahydropyranyloxyalkanes were reacted with compounds 1 and 2 in the presence of $\text{PdCl}_2(\text{PPh}_3)_2$ (*Z*-isomers) or $\text{NiCl}_2(\text{dppe})$ (*E*-isomers) to give 1-phenylthio- ω -tetrahydropyranyloxyalk-1-enes with yields in the range 71-86%. The second cross-coupling reaction performed in the presence of a catalytic amount of the Ni complex led to the tetrahydropyranyl-protected alkenols which were subjected directly to acetylation with acetic anhydride to give the corresponding acetates. The yields were in the range 73-81% and the stereoselectivity was 97-98% for the (*Z*)-isomers and >99% for the (*E*)-isomers. In Table 2 the names of the insect species corresponding to the pheromones prepared are reported.

Scheme 5

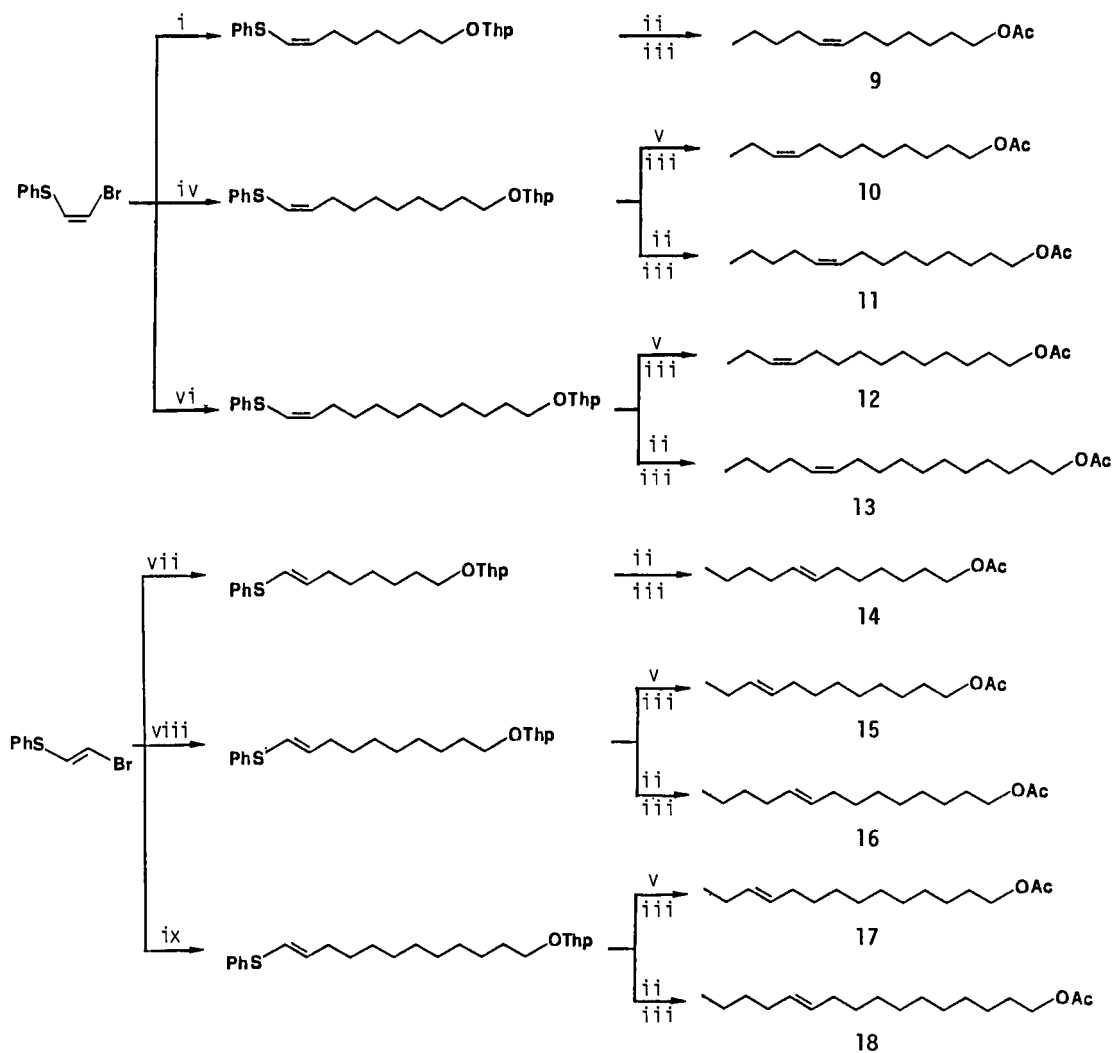

Reagents: i, $\text{ThpO}(\text{CH}_2)_6\text{MgCl}$, $\text{PdCl}_2(\text{PPh}_3)_2$; ii, $n\text{-C}_4\text{H}_9\text{MgBr}$, $\text{NiCl}_2(\text{dppe})$; iii, Ac_2O ; iv, $\text{ThpO}(\text{CH}_2)_8\text{MgBr}$, $\text{PdCl}_2(\text{PPh}_3)_2$; v, $\text{C}_2\text{H}_5\text{MgBr}$, $\text{NiCl}_2(\text{dppe})$; vi, $\text{ThpO}(\text{CH}_2)_{10}\text{MgBr}$, $\text{PdCl}_2(\text{PPh}_3)_2$; vii, $\text{ThpO}(\text{CH}_2)_6\text{MgCl}$, $\text{NiCl}_2(\text{dppe})$; viii, $\text{ThpO}(\text{CH}_2)_8\text{MgBr}$, $\text{NiCl}_2(\text{dppe})$; ix, $\text{ThpO}(\text{CH}_2)_{10}\text{MgBr}$, $\text{NiCl}_2(\text{dppe})$.

TABLE 2

Pheromone component		Insect species
(<u>Z</u>)-Dodec-7-enyl acetate	9	Cabbage looper (<i>Trichoplusia ni</i>), soybean looper (<i>Pseudoplusia includens</i>)
(<u>Z</u>)-Dodec-9-enyl acetate	10	European grapeberry moth (<i>Eupoecilia ambiguella</i> , <i>Paralobesia viteana</i>)
(<u>Z</u>)-Tetradec-9-enyl acetate	11	Smaller tea tortrix (<i>Adoxophyes fasciata</i>), black cutworm (<i>Agrotis ipsilon</i>), fall armyworm (<i>Spodoptera frugiperda</i>)
(<u>Z</u>)-Tetradec-11-enyl acetate	12	Obliquebanded leafroller (<i>Choristoneura rosaceana</i>), redbanded leafroller (<i>Argyrotaenia velutinana</i>), filbert leafroller (<i>Archips rosanus</i>)
(<u>Z</u>)-Hexadec-11-enyl acetate	13	Cabbage armyworm (<i>Mamestra brassicae</i>), bertha armyworm (<i>Mamestra configurata</i>)
(<u>E</u>)-Dodec-7-enyl acetate	14	False codling moth (<i>Cryptophlebia leucotreta</i>)
(<u>E</u>)-Dodec-9-enyl acetate	15	European pine shoot moth (<i>Rhyacionia buoliana</i>)
(<u>E</u>)-Tetradec-9-enyl acetate	16	<i>Loxostege neoblitalis</i> , <i>Polia grandis</i>
(<u>E</u>)-Tetradec-11-enyl acetate	17	<i>Archips mortuanus</i> , spotted fireworm (<i>Choristoneura parallela</i>)
(<u>E</u>)-Hexadec-11-enyl acetate	18	Sweet potato leaf folder (<i>Brachmia macroscopa</i>)

SYNTHESIS OF DIENES AND ENYNES (ref. 14)

We are continuing to explore the synthetic potential of our olefin synthesis. Although the results of our investigation will be fully reported at a later date, it seems appropriate to anticipate in this lecture a few relevant results.

(i) Our procedure can be conveniently extended to prepare 1,6-dienes (ref. 16). An example is represented by the synthesis of (6E,11E)-hexadecadienol reported in Scheme 6.

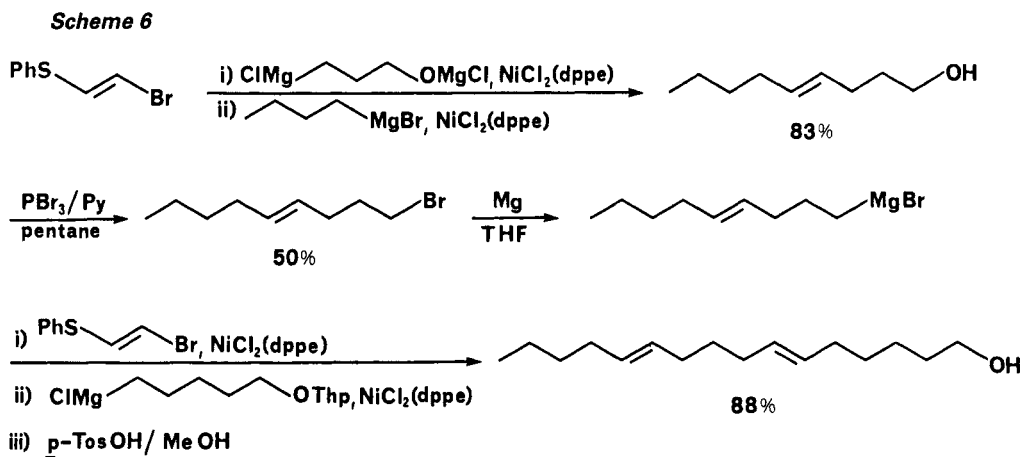

(ii) Conjugated dienes can be easily prepared by using vinylic Grignard reagents as shown by the synthesis of (E)-9,11-dodecadien-1-yl acetate, a sex pheromone component of the red bollworm moth (*Diparopsis castanea*) (Scheme 7).

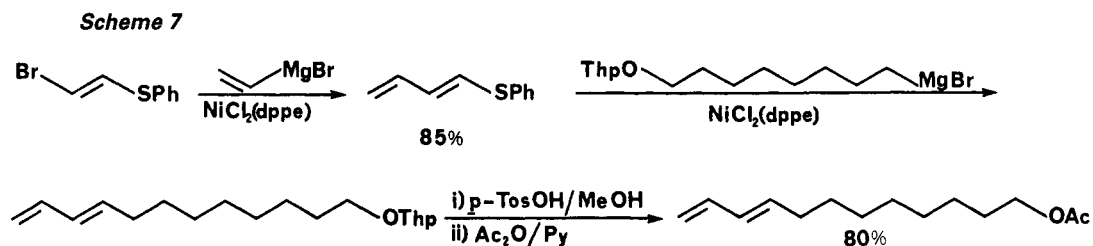

The stereospecific synthesis of 1-silylated dienes was accomplished by reacting compounds 1 and 2 with (E) 2-silylvinylmagnesium bromide according to eq. 1.

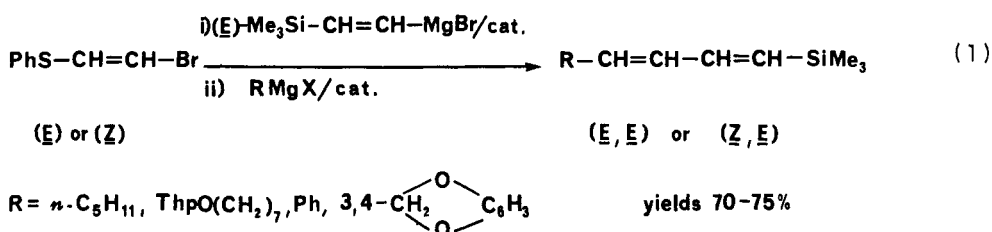

This class of compounds is of special interest due to the well known versatility in Diels-Alder reactions (ref.17) and in other processes which involve the substitution of the silyl group such as the synthesis of carbonyl compounds with a diene structure, according to eq.2 (ref. 18).

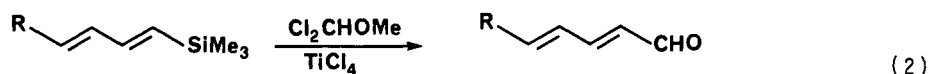

Our contribution to the expansion of the synthetic potential of these silylated dienes is represented by a simple synthesis of methyl 9-oxo-(10E,12E)-dodecadienoate which by hydrolysis and reduction should be easily transformed into β-dimorphecolic acid (Scheme 8). This compound together with the (10E,12Z-isomer) (α-dimorphecolic acid) has attracted considerable interest (ref. 19).

Scheme 8

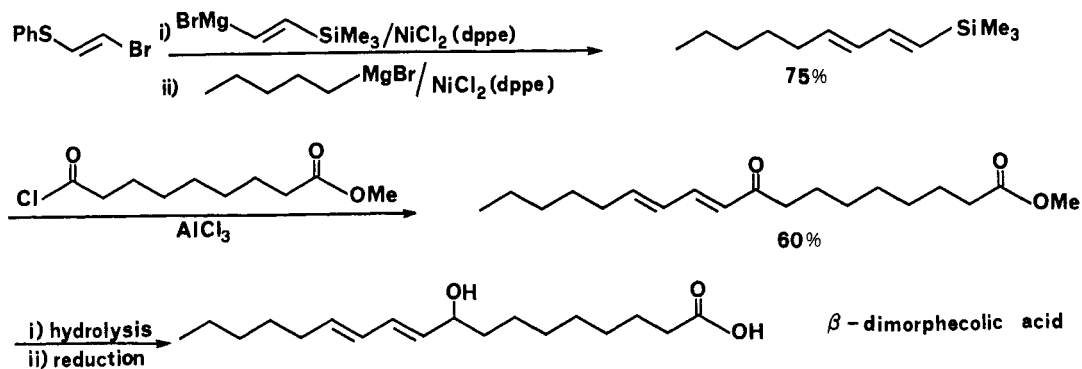

Furthermore, we found that by reacting silylated 1,3-butadienes with PdCl₂/CuCl₂, following the procedure described for vinylsilanes (ref. 20), it is possible to obtain a homocoupling process, as shown in eq. 3 for the synthesis of 1,8-diphenyl-octa-(1E,3E,5E,7E)-tetraene.

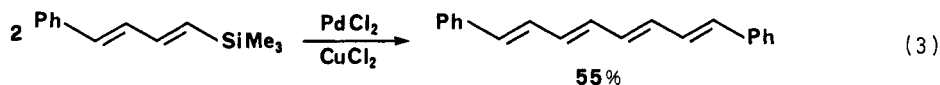

Finally, it was found that the silyl-group in these compounds can be replaced by a bromine atom by reaction with BrCN, following the procedure reported for vinylsilanes (ref. 17b), thus obtaining isomeric 1-bromo-4-phenylthio-1,3-butadienes (eq. 4).

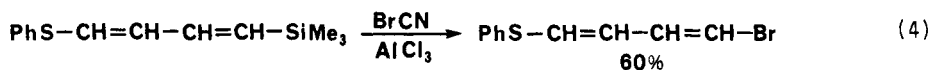

These compounds represent the dienic counterparts of mono-olefins 1 and 2. Therefore, a variety of novel syntheses based upon the different reactivity of the two leaving groups can be envisaged.

(iii) Conjugated 1-silyl-enynes can be obtained in a manner analogous to the synthesis of 1-silyl-1,3-dienes (eq. 5). 1,3-Enynes are known to undergo a variety of synthetically useful transformations (ref. 21).

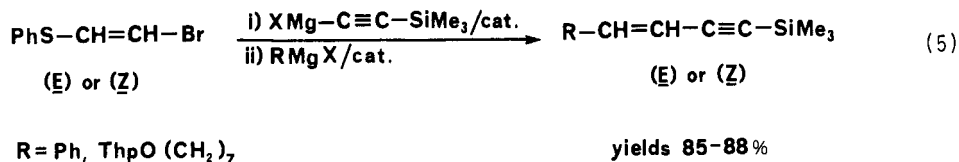

(iv) Besides Grignard reagents other organometallic compounds are being evaluated in cross-coupling reactions with substrates 1 and 2. Dialkyl cuprates such as di-*n*-butyl cuprates react smoothly. However, (*Z*)-alkenyl cuprates generated according to the Normant procedure and used in the conditions normally adopted for vinyl halides (ref.8) gave unsatisfactory results. Thus, we adopted a variation of our procedure by transforming the (*Z*)-isomer 1 into phenylthioacetylene and adding smoothly the alkenyl cuprate reagent. This variation of our normal procedure is illustrated by the synthesis of bombykol, the sex-pheromone of the silkworm moth (*Bombyx mori*) (Scheme 9).

Scheme 9

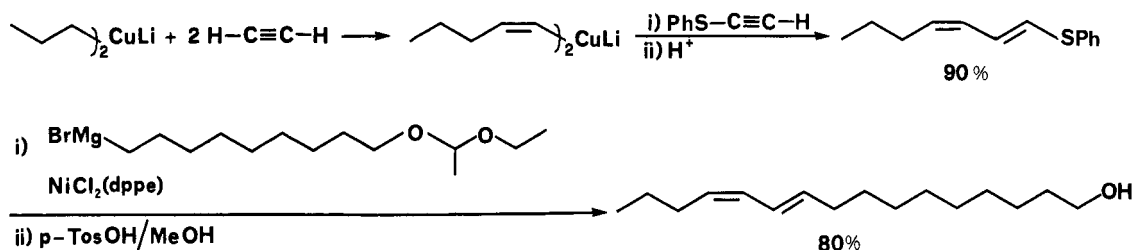

(v) The synthesis of dienes from compounds 1 and 2 is attracting the interest of other workers. Recently Suzuki, Mijaura and Ishiyama (ref. 22) have used our building blocks in the cross-coupling reactions with 1-alkenyl-1,3,2-benzodioxaborole in the presence of Pd(PPh₃)₄ and a base (eqs. 6 and 7).

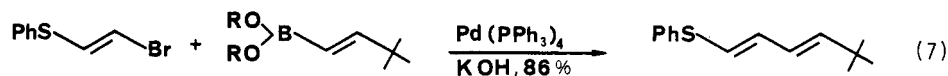
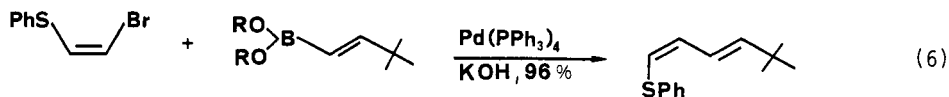

Furthermore, they have extended our procedure using (*E*)- or (*Z*)-2-bromo-1-phenylthio-1-propene as starting materials and some of the products have been subjected to the second cross-coupling reaction with Grignard reagents. The usefulness of the procedure has been demonstrated by the synthesis of (2*E*,4*E*,6*E*)-3,7,11-trimethyl-(2,4,6,10)-dodecatetraene *cis*(C₁₀)-allofarnesene and 1-(2,6,6-trimethylcyclohexen-1-yl)-3,6-dimethyl-(1*E*,3*Z*)-(1,3,5)-heptatriene (Scheme 10).

Scheme 10

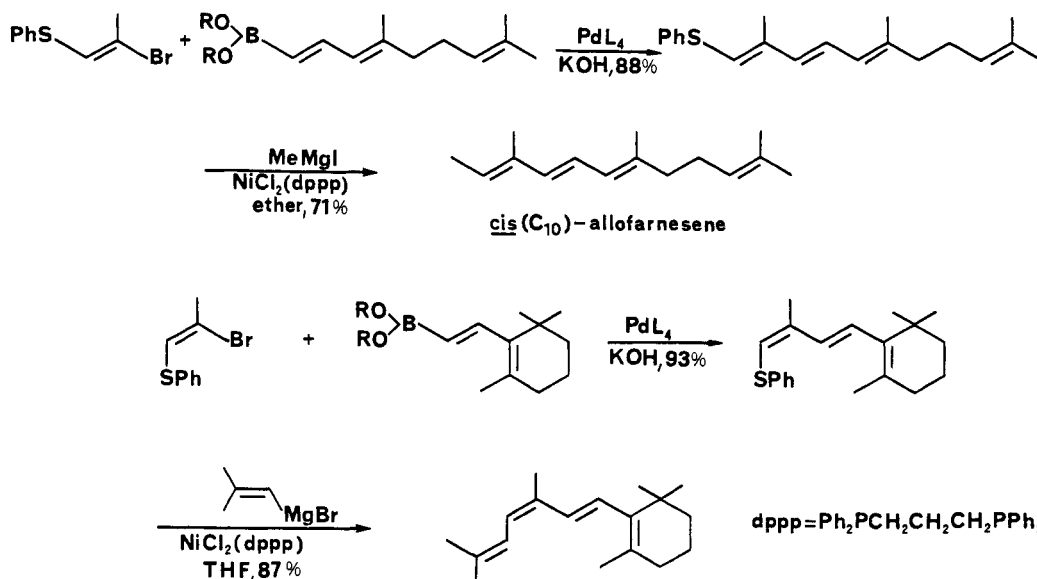

SYNTHESIS OF 1,1-DISUBSTITUTED ETHENES

The sequential cross-coupling process can be extended to 1,1-disubstituted ethenes by using 1-chloro-1-phenylthioethene as a substrate according to eq. 8 (ref. 23).

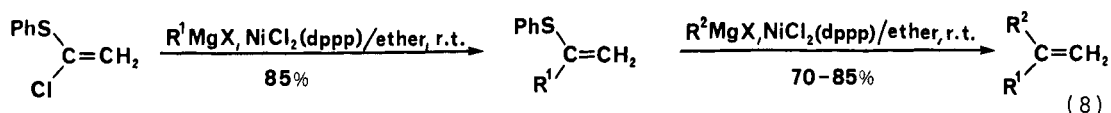

$\text{R}^1 = \text{Me}$ or $n\text{-Bu}$; $\text{R}^2 = \text{Ph}$

However, the lack of any stereochemical requirement in this synthesis has led us to use a commercial starting material (i.e. 2,3-dibromopropene) as a multicoupling component, in which substitution of the bromine atom at the allylic carbon occurs in the absence of any catalyst, whereas the vinylic substitution requires the use of the catalyst (eq. 9). Taking advantage of this difference, several compounds (including silylated dienes) were prepared (ref.23).

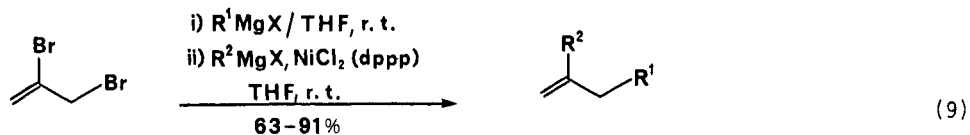

$\text{R}^1 = n\text{-Bu, } n\text{-C}_7\text{H}_{15}, n\text{-C}_8\text{H}_{17}, \text{PhCH}_2$; $\text{R}^2 = \text{Me, } n\text{-Bu, CH}_2=\text{CH, Me}_3\text{Si-CH}=\text{CH, Ph, PhCH}_2$

CONCLUSION

Taking into accounts (i) the mild reaction conditions (ii) the simplicity of the operations involved, (iii) the relatively high overall yields, and (iv) the high stereospecificity, our method appears to rank among the most useful procedures presently available for the synthesis of substituted ethenes. As shown above, dienes can also be prepared and the work in progress eventually should lead to an equally easy route to compounds having two or more double bonds with the required geometry.

Acknowledgement

The author wishes to express his appreciation to his coworkers and students who have contributed their enthusiasm and hard work to the investigations described above. Partial support of this work by the Ministero Pubblica Istruzione (Rome) is gratefully acknowledged.

REFERENCES

1. G.H. Posner, An Introduction to Synthesis Using Organocopper Reagents, Wiley, New York (1980); F. Naso, Chim. Ind. (Milan), **61**, 473-482 (1979).
2. F. Naso and G. Marchese, The Chemistry of Functional Groups, Supplement D: The Chemistry of Halides, Pseudo-Halides and Azides, p. 1353, eds. S. Patai and Z. Rappoport, Wiley, New York, (1983).
3. E. Negishi, Acc. Chem. Res., **15**, 340-348 (1982); P.W. Jolly, Comprehensive Organometallic Chemistry, p. 713, eds. G. Wilkinson, F.G.A. Stone and E.V. Abel, Pergamon Press, New York (1982); M. Kumada, Pure Appl. Chem., **52**, 669-679 (1980).
4. C.V. Maffeo, G. Marchese, F. Naso and L. Ronzini, J. Chem. Soc., Perkin I, 92-97 (1979); V. Fiandanese, G. Marchese and F. Naso, J. Organomet.Chem., **162**, C13-16 (1978).
5. Z. Rappoport, Recl. Trav. Chim. Pays Bas, **104**, 309-349 (1985); G. Modena, Acc. Chem. Res., **4**, 73-80 (1971).
6. V. Fiandanese, G. Marchese and F. Naso, Tetrahedron Lett., 5131-5134 (1978).
7. G. De Chirico, V. Fiandanese, G. Marchese, F. Naso and O. Sciacovelli, J. Chem. Soc., Chem. Comm., 523-524 (1981).
8. M. Gardetti, N. Jabri, A. Alexakis and J.F. Normant, Tetrahedron, **40**, 2741-2750 (1984) and references therein.
9. E. Angeletti, F. Montanari and A. Negrini, Gazz. Chim. Ital., **87**, 1086-1101 (1957).
10. V. Fiandanese, G. Marchese, F. Naso and L. Ronzini, J. Chem. Soc., Chem. Comm., 647-649 (1982).
11. V. Fiandanese, G. Miccoli, F. Naso and L. Ronzini, J. Organomet. Chem., **312**, 343-348 (1986).
12. T. Hayashi and M. Kumada, Asymmetric Synthesis, vol. 5, p. 147, ed. J.D. Morrison, Academic Press, New York, (1985).
13. C. Cardellicchio: Ph.D. Thesis (in progress), Department of Chemistry, University of Bari, Italy.
14. Unpublished results.
15. V. Fiandanese, G. Marchese, F. Naso and L. Ronzini, J. Chem. Soc., Perkin I, 1115-1119 (1985).
16. For a preliminary communication see: V. Fiandanese, G. Marchese, F. Naso and L. Ronzini, Abstracts of the Third IUPAC Symposium on Organometallic Chemistry Directed toward Organic Synthesis, Kyoto, Japan, p. 169 (1985).
17. a) M.J. Carter, I. Fleming and A. Percival, J. Chem. Soc., Perkin I, 2415-2434 (1981); b) T.H. Chan and I. Fleming, Synthesis, 761-786 (1979).
18. K. Yamamoto, M. Ohta and J. Tsuji, Chem. Lett., 713-716 (1979).
19. S. Tsuboi, S. Maeda and A. Takeda, Bull. Chem. Soc. Jpn., **59**, 2050-2052 (1986); A.V. Rama Rao, E. R. Reddy, G.V.M. Sharma, P. Yadagiri and J.S. Yadav, Tetrahedron Lett., **26**, 465-468 (1985); H. Suemune, N. Hayashi, K. Funakoshi, H. Akita, T. Oishi and K. Sakai, Chem. Farm. Bull., **33**, 2168-2170 (1985); R.C. Badami and L. J. Morris, J. Am. Oil Chem. Soc., **42**, 1119-1121 (1965); L.J. Morris, R.T. Holman and K. Fontell, ibid., **37**, 323-327 (1960).
20. V.P. Weber, R.A. Felix, A.K. Willard and K.E. Koenig, Tetrahedron Lett., 4701-4704 (1971).
21. H.C. Brown, N.G. Bhat and D. Basavaiah, Synthesis, 674-676 (1986) and references therein.
22. T. Ishiyama, N. Miyaara and A. Suzuki, Chem. Lett., 25-28 (1987).
23. V. Fiandanese, G. Marchese, F. Naso and L. Ronzini, Synthesis, in press.