

High temperature processing and numerical modelling of thermal plasmas in Norway

J.A. Bakken

Dept. of Metallurgy, The Norwegian Institute of Technology
N-7034 Trondheim, Norway

Abstract.

This report overviews past and present thermal plasma research activities in Norway. Two of the main areas are *applications* of plasma technology in silicon and ferrosilicon processing and *numerical modelling* of transferred and free-burning arcs in reactor or furnace environments. Some results are proprietary to industrial companies and cannot be discussed here. AC arcs are also being studied. The work described has primarily been done in Trondheim at the research institute SINTEF Metallurgy and by Dr.ing. students at the Norwegian Institute of Technology, Department of Metallurgy.

Introduction.

Research on applications of thermal plasmas has old traditions in Norway. In 1903 the physicist Kristian Birkeland in cooperation with the engineer Sam Eyde patented a procedure for "Production of Nitreous Compounds from Air using *flat electric sparks* or disk shaped flames". An expanded 50 Hz AC discharge between two water-cooled electrodes was created by applying a DC magnetic field perpendicular to the electrodes.

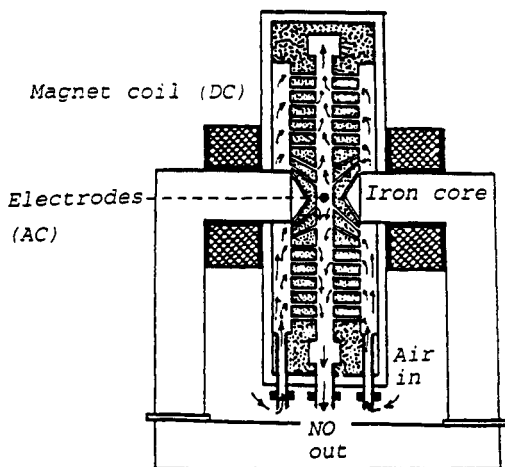

As shown in Figure 1, where the electrodes are normal to the paper plane, the field was generated by a large iron-cored coil. The arc chamber was only a few inches wide and lined with refractory bricks. NO was formed when air was blown through the lining and radially through the plasma disk. The final products were *nitric acid* and *nitrogen fertilizer*. The arc power of the largest "flame furnaces" was 4 MW. Despite the relatively high electric energy consumption, 16 kWh per kg HNO₃, the Birkeland-Eyde process was run profitably by Norsk Hydro for 20 years.

Figure 1. Birkeland-Eyde "flame furnace".

Metallurgical and chemical processing.

In the 70's there was some interest in Norway for using DC plasma torches instead of consumable Söderberg electrodes in conventional *submerged-arc furnaces* for ferroalloy smelting - in particular in the ferrosilicon process. Laboratory tests were done, but the development of reliable plasma torches for transferred arc operation in excess of 10 MW seemed to be very far ahead (and still is ?).

A transferred arc was used with considerable success as the heat source for the first step of a continuous laboratory reactor for production of *silicon carbide* from quartz sand and coke:

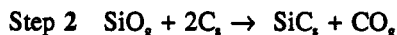
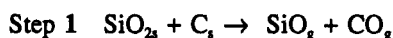

Around 80-85 the *immersed plasma lance* for heating liquid metals emerged /1/. In this device a DC arc burns radially between an outer tubular electrode - normally the cathode - and a central graphite rod electrode, which is slightly retracted. A gas stream expels the metallic melt from the annular inter-electrode space so that short-circuiting is avoided - see Figure 2.

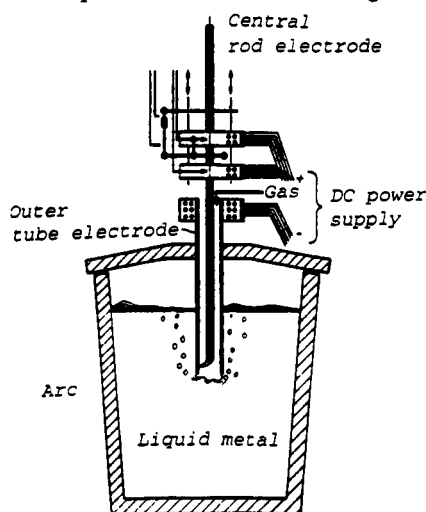

Figure 2. Immersed plasma lance.

Originally, the "normal" polarity with a cathodic rod electrode was used. It turned out, however, that the electric instability due to upstream penetration of metal droplets into the discharge region between the electrodes was greatly reduced when the polarity was reversed. It was thought that the metal droplets were swept out by the more intense axially directed anode jet from the rod electrode. Immersed operation with the arc (actually several sub-arcs in parallel) burning 0.5-1 m below the surface of the liquid metal was successfully obtained.

Two industrial MW-sized units were tested in ferrosilicon contained in 3 m³ ladles. The main problem hampering commercial use of the immersed lance is to find a suitable graphite quality able to withstand the extreme thermal tensions caused by the arcs. In the steel works the problem is to design a water or preferably oil-cooled tube electrode for prolonged immersed operation in liquid steel.

The present thermal plasma activities began in 87 when a plasma research group was established at NTH/SINTEF with support from The Royal Norwegian Council for Scientific and Industrial Research and the Norwegian ferro industry.

The experimental facility PRESS depicted in Figure 3 /2/ includes a multi-purpose graphite lined reactor with one or three plasma torches (Plasma Systems model PS-400), and three separate DC power supplies with current rating 500 A and max voltage 300 V DC. In the single torch case the three power units may be connected in parallel or in series to obtain a high current or a high voltage. An extensive experimental program has been completed in various versions of the PRESS reactor:

Remelting of silicon metal fines has been successfully done in the PRESS reactor, which proved itself as a smoothly functioning melting device with short response time and excellent temperature control /2/. The estimated remelting capacity during hypothetical continuous operation with nitrogen was 93 kg/h corresponding to a specific energy consumption of 1.7 kWh/kg fines. The loss of fine particles was insignificant.

Ultrafine silica particles have been produced by feeding Si-metal ("Silgrain") and SiO₂ as quartz sand into a special version of the PRESS reactor - see Figure 4 /2/. The SiO-gas formed on the surface of the silicon metal bath by the strongly endothermic reaction

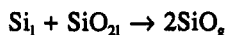

was oxidized to SiO₂ and quenched by a large surplus of cold air. The "Nanosilica" powder collected in the filter bags had a surface area of 250 m²/g, high purity > 99.6% and high reflectivity > 90%.

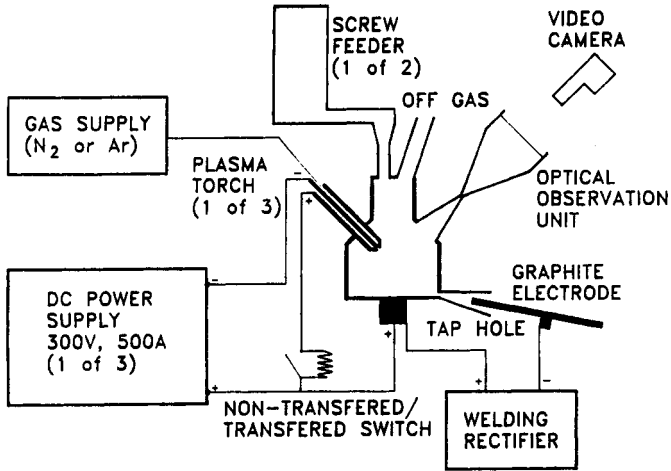

Figure 3. The PRESS experimental set-up.

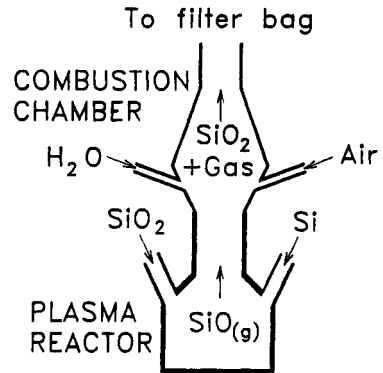
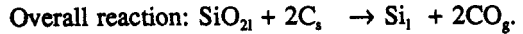
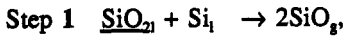
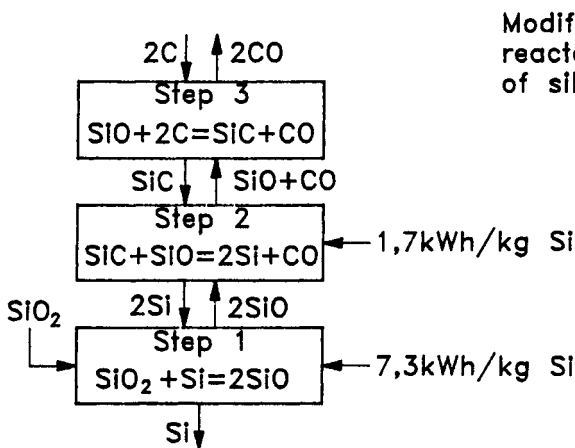

Figure 4. Ultrafine silica process.

A novel *three-step process for silicon metal* produced from quartz and coke has been proposed based on experiments and Si-O-C reaction mechanism studies in the PRESS reactor. The flow sheet and the experimental set-up are shown in Figure 5 [2]. The three process steps are:



All the SiO₂ consumed by the process is fed to the highly endothermic Step 1, where the transferred arcs supply the heat. To maintain the required temperature level of 2000°C in the metal producing Step 2 approximately 16 % of the total electric energy must be added here. All the carbon is added in Step 3. Theoretically, the specific energy consumption is 9.3 kWh per kg silicon metal by a Si yield of 97 %.



Modified 300kW PRESS reactor for production of silicon metal:

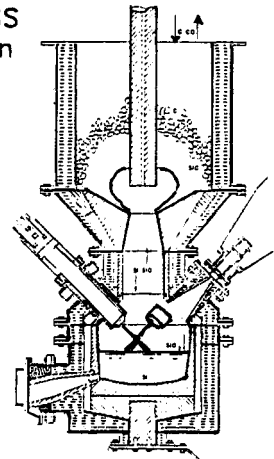

Figure 5. The three-step silicon process.

A special *submerged centrifugal plasma device* for heating liquid aluminium by refining and alloying has been developed in cooperation with Hydro Aluminium - see Figure 6. Several units are now in industrial use (K. Venås et al.) [3].

Pyrolysis of chlorinated hydrocarbon wastes was studied using a special version of the immersed graphite lance. Other gas processing applications, e.g. with magnetically rotated arcs, are developed in co-operation with industrial companies. The rotation, which is brought about by a DC magnetic field, ensures that a uniform and symmetric plasma jet emerges from the lance. The axial position of the arc(s) is also controlled by suitable field configurations. Unfortunately, no details can be disclosed.

Extensive *measurements* have been undertaken in a *calorimetric 1:1 cold-wall model* of the PRESS reactor to determine the heat flux distribution on the various parts of the reactor walls and the metal pool with one or with three arcs (shown in Figure 7), and with Ar and N₂ as plasma gas. The calorimetric model is equipped with the same plasma torches and operated at the same power level as the PRESS reactor. Almost 100 % of the electrically generated energy is recovered as heat in the cooling-water circuits including the off-gas heat exchanger. The experiments generally agree quite well with simulations - see Figure 8. Wall heat fluxes and current-voltage characteristics for transferred *nitrogen arcs* will be presented at ISPC-11 (A.E. Arntsberg, R. Jensen, J.A. Bakken).

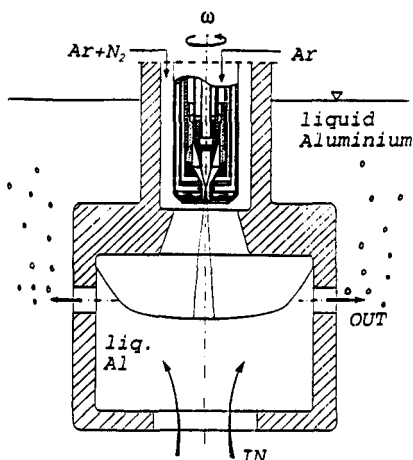

Figure 6. The Hydro Aluminium rotor for heating and refining.

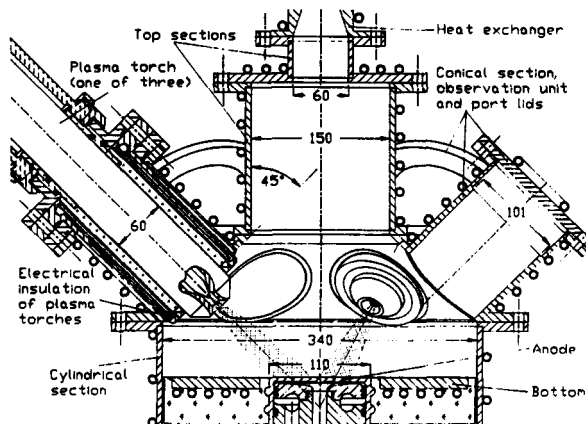
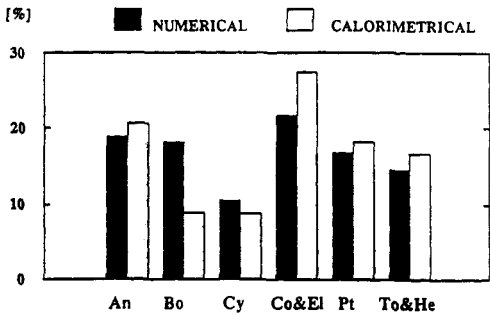

Figure 7. The calorimetric model, triple torch version.

Mathematical modelling.

Modelling of non-transferred and transferred DC arcs has been and still is an important activity. Heat transfer and other interactions between the arcs and the reactor walls and the electrodes are emphasized.

In the *2D models of transferred nitrogen arcs* to be published later (A.E. Arntsberg) the main emphasis is on the cathode boundary condition for the current and on reabsorption of radiation. The simulation results are compared with measurements in the single torch version of the cold-wall calorimeter. Simulations are also done on nitrogen *cascade arcs*. The calculated temperature distributions and electric fields agree well with other author's measurements. 2D models of *free-burning* as well as transferred *argon arcs* with various boundary conditions have also been developed.



Computed distribution of the heat losses compared to measured values in the tripple torch calorimeter. An = Anode, Bo = Bottom section minus anode, Cy = Cylindrical wall section, Co = Conical wall section, El = Electrical insulation around torches, Pt = Plasma torch(-es), To = Top wall section, He = Heat exchanger on top of the reactor

3D models have been made of the PRESS reactor with three tilted arcs in argon. The thermally isolated composite lining and the metal pool are included in the computational domain. Arc-to-wall and wall-to-wall radiation are taken into account. Thus the heat distribution as well as the wall surface temperatures are computed - see Figures 8 and 9. Although the model is based on the "prescribed current distribution" approximation, the agreement with the calorimetric results is satisfactory. The predicted thermal efficiency is 45 % compared to 41 % measured during silicon remelting tests. The discrepancy could be due to uncertain thermal conductivity data for the materials used in the reactor lining (Carbon Black and "Tri-Mor"). Further results were presented at ISPC-10 (N.J. Holt et al.) /4/.

Figure 8. Measured and simulated heat distribution in the calorimetric model.

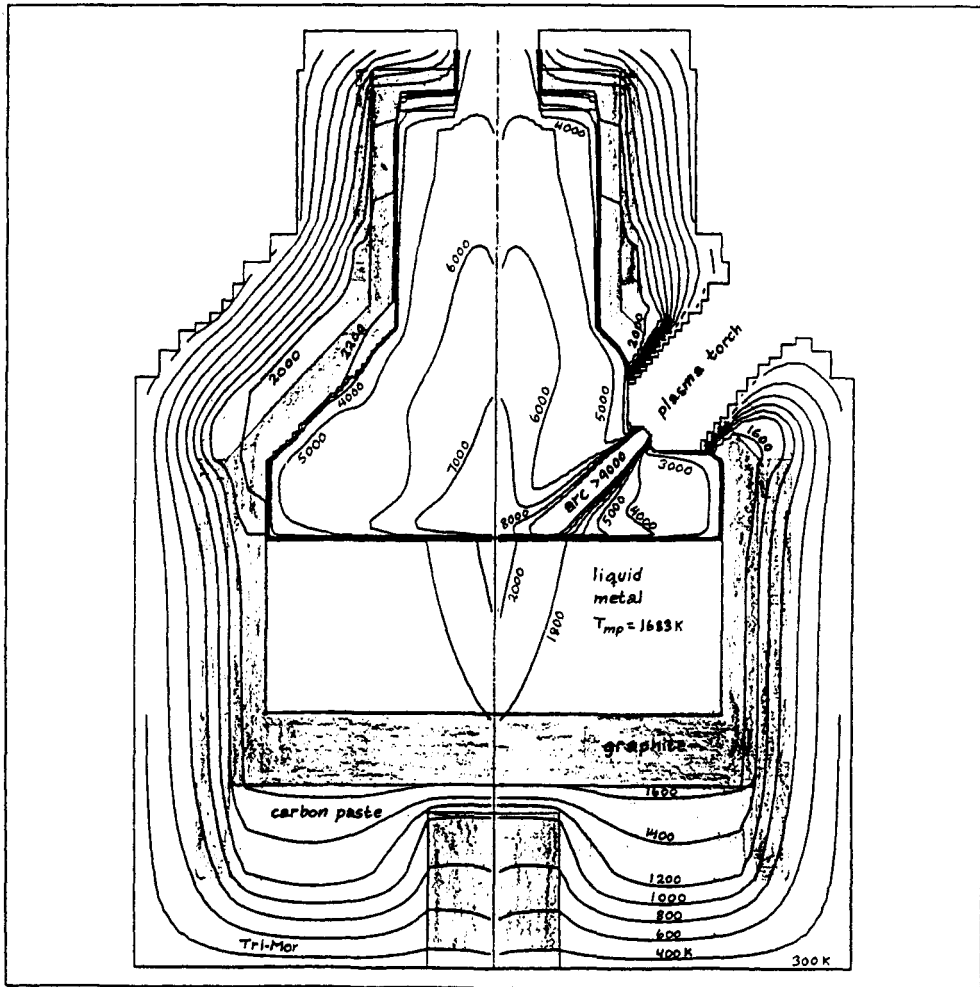

Figure 9. Temperature distribution in the PRESS reactor. The computational domain includes the composite refractory lining.

In plasma processes involving silicon metal the transferred arcs will be *infiltrated by silicon vapor*, which must be expected to affect arc behaviour. Computer programs have been made to calculate thermo-dynamic, transport and radiation properties of *Ar-Si plasmas* [5]. Three examples are given in Figure 10: a) composition, b) electric conductivity and c) net volumetric radiation density of an Ar-Si plasma with atomic ratio = 1:1.

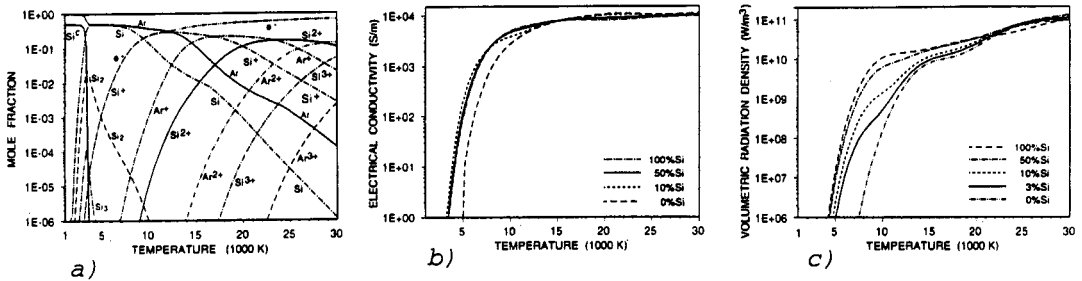

Figure 10. a) Composition (molar fraction) of Ar-Si plasma with atomic ratio 1:1, b) Electric conductivity, c) Volumetric radiation density.

This work is now being extended to *4-component Si-O-C-Ar plasmas*, which are of great interest when modelling the AC arcs in industrial submerged-arc furnaces or DC arcs in plasma reactors for silicon metal or ferrosilicon. Chemical composition and radiative properties are calculated as functions of atomic ratio Ar:Si:O:C and temperature by V.G. Sevast'yanenko, with whom we now have a close collaboration. 34 molecular, atomic and ionic species are taken into account. The composition must be known with sufficient accuracy in order to calculate the transport properties of the plasma mixtures. It might be appropriate to mention that the Trondheim group was probably the first outside Russia to employ *Sevast'yanenko's method of partial characteristics* [6] to calculate radiation in plasmas [7].

The complex *interaction between an argon arc and its evaporating anodic metal pool* has been simulated for the free-burning as well as the transferred arc case by two coupled models [8]:

- i) The plasma phase model, where the *species* continuity equation is solved together with the mass, momentum, energy and electric current equations. A "quasi-binary" diffusion coefficient is introduced.
- ii) The metal pool model, where the flow and temperature fields are calculated taking electro-magnetic and buoyancy forces as well as jet momentum and Marangoni effects into account.

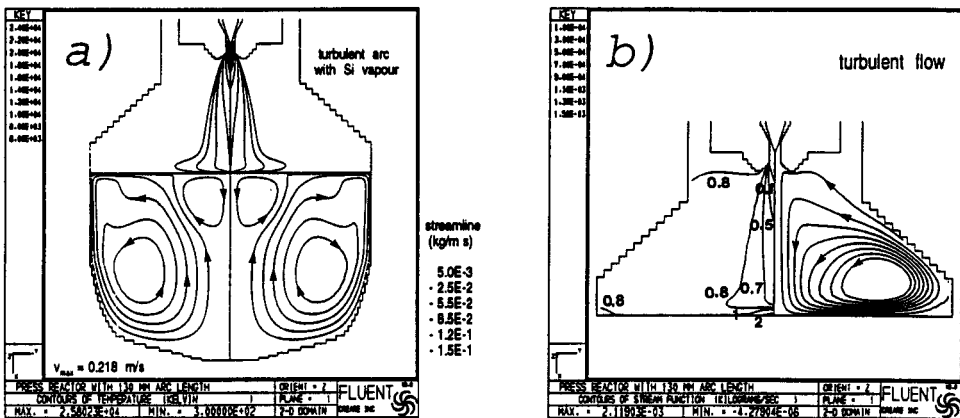

Figure 11. Simulations of reactor with a 130 mm long, 1000 A transferred arc and a silicon metal pool: a) Temperature in plasma and stream lines in pool, b) Wt-% Si and stream lines in plasma.

As an example, the temperature and silicon vapour distributions and the stream line patterns in a reactor with a 130 mm long, 1000 A, 30 NI Ar/min transferred arc and an anodic silicon metal pool are shown in Figures 11a and b. Further details and results - e.g. concerning the effect on the arc voltage of varying the metal vapour concentration from 0 to 100 % - will be given at ISPC-11 (Gu Liping et al.).

AC arc modelling.

Numerical modelling of 2D 50 Hz AC arcs is in progress based on the previously developed DC models. A main purpose of this work is to develop an AC arc model which can be incorporated in a "complete" quantitative description of heat, mass and momentum transfer and chemical reactions in the interior of the submerged arc processes for production of silicon metal and ferrosilicon. Thermodynamic, transport and radiative properties of Si-O-C plasmas will then be needed. A problem that must be addressed is the cathode boundary conditions that alternate between the "electrode" (e.g. graphite or Söderberg electrode) and the "counter-electrode" (e.g. metal pool).

Figure 12 refers to preliminary "channel model" simulations for a 0.1 m long arc in a 40 MVA ferrosilicon (FeSi75) furnace and shows the arc voltage and current over a period. The current-voltage lissajous curve is typical and reveals the super-harmonics. The *external circuit* including the transformer secondary voltage, the reactance and loss resistance is taken into account [9]. This model is employed in a work which will be presented at ISPC-11 (Ingason, Bakken).

As in all our previous simulations the fluid flow and heat transfer simulation program FLUENT will also be used for AC arcs. The computational time needed for obtaining convergent time-dependent solutions is, however, expected to be considerable.

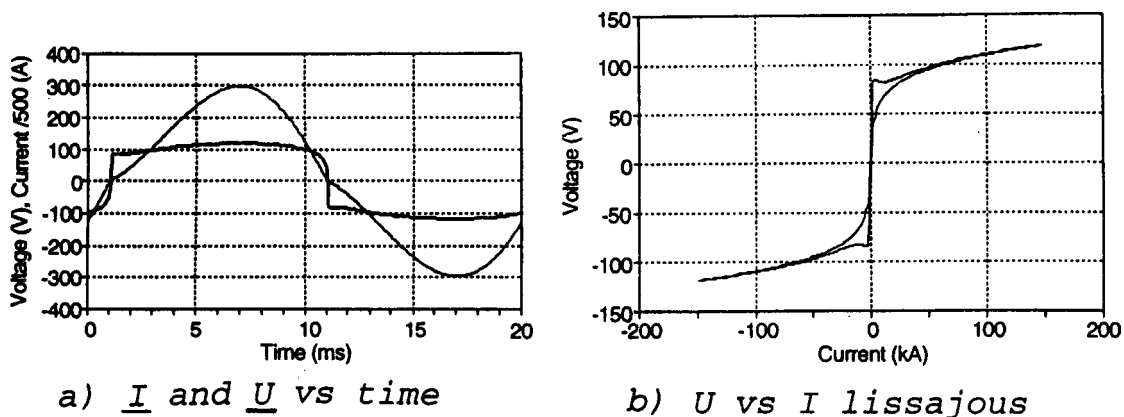

Figure 12. a) Arc voltage and current during a 50 Hz period for a 100 mm long arc in a 40 MVA submerged-arc ferrosilicon furnace, b) Current-voltage lissajous curve.

Acknowledgements.

Thanks are due to all who have contributed to the projects mentioned in this report, in particular: R. Jensen, O. Raaness and K. Venås of SINTEF Metallurgy, and A.E. Arntsberg, Liping Gu, N.J. Holt and H.L. Larsen of The Norwegian Institute of Technology.

This work has been supported by The Research Association of the Norwegian Ferroalloys Industry, The Royal Norwegian Research Council and private companies.

References.

1. Bakken, J.A., Raaness, O., Bakken, T. and Svensen, O.H., *Immersed Plasma Heater for Liquid Metals*, Union Int. d'Electrothermie 10th Congress, Stockholm, Sweden, Aug. 1984.
2. Bakken, J.A. and Jensen, R., *Plasma Research at the Norwegian Institute of Technology*, Plasma for Industry and Environment, Oxford, England, Sept. 1990.
3. Myrbostad, E., Pedersen, T., Venås, K. and Johansen, S.T., *The ÅSV In-Line System for Refining of Aluminium*, Light Metals 1986, New Orleans, USA, March 1986.
4. Holt, N.J., Bakken, J.A. and Jensen, R., *Heat Transfer in a Plasma Reactor with Three Transferred Arcs*, 10th Int. Symp. on Plasma Chemistry, Bochum, Germany, Aug. 1991.
5. Gu, L., Arntsberg, E.A. and Bakken, J.A., *The Influence of Silicon Vapour on the Transport Coefficients and the Arc Behaviour in an Argon Plasma*, 10th Int. Symp. on Plasma Chemistry, Bochum, Aug. 1991
6. Sevast'yanenko, V.G., Ch. 3 in Soloukhin, R.I., *Handbook of Radiation Heat Transfer in High Temperature Gases*, Hemisphere Publ. Corp., 1987, transl. from the original Russian ed., Energoatomizdat, Moscow, 1984.
7. Arntsberg, E.A., Gu L., and Bakken, J.A., *Mathematical Modelling of Plasma Arc Radiation: Comparison of the Optically Thin Gas Approximation with the Integral Method of Partial Characteristics*, J. High Temp. Chem. Processes, Vol.1, p.45, 1992.
8. Gu, Liping, *Transport Phenomena in Silicon Vapour Infiltrated Argon Arcs and Anodic Metal Pools*, Ph.D. thesis, Dept. of Metallurgy, The Norwegian Inst. of Techn., Trondheim, Norway, April 1993.
9. Larsen, H.L., *Channel model for AC electric arcs*, SINTEF Metallurgy, Trondheim, Norway, rpt. STF A931113, 1993.